

Machine Controller CP-9200SH/PO-01

MOTION CONTROLLER USER'S MANUAL

PULSE-OUTPUT TYPE

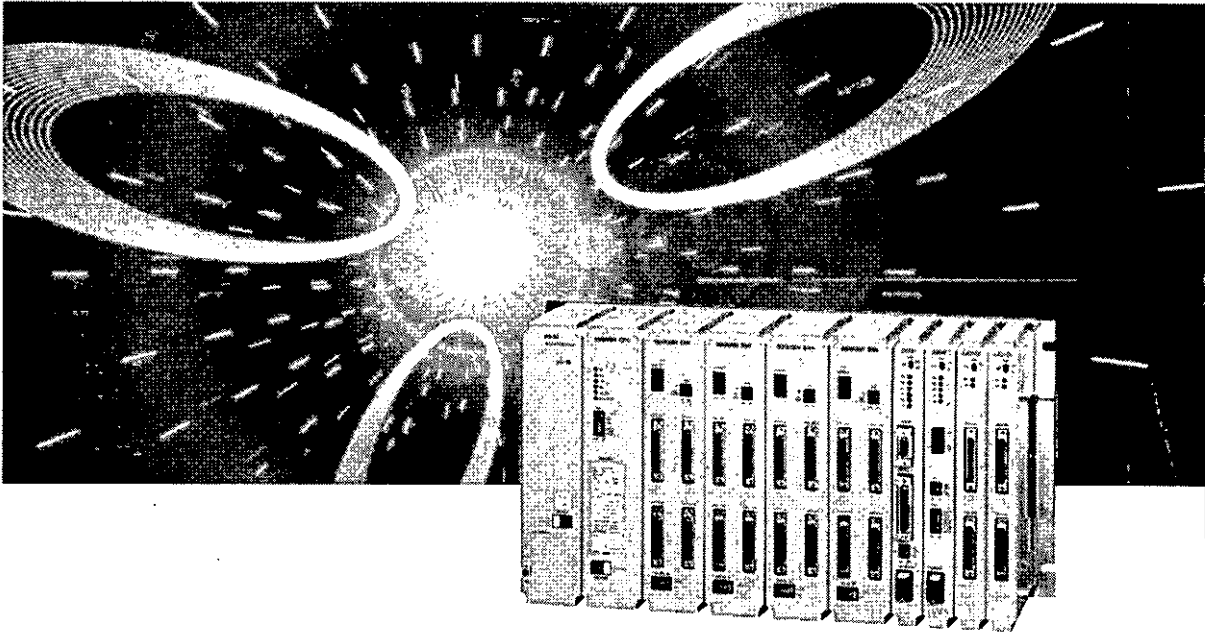

Introduction

This is the User's Manual for the Pulse-output Motion Controller. This provides information about a motion module, PO-01, one of the modules for Machine Controller CP-9200SH (hereafter called "CP-9200SH").

This manual describes the software for the PO-01 module (the basic specification, functions, examples of user's programs, and motion parameters). Refer to the "CP-9200SH User's Manual" for the hardware of the PO-01 module (the outline drawing, display lamps, setting switches, connectors, and examples for connecting to motion drives).

The CP-717, which is described in the document, refers to the Control Pack CP-717 (hereafter called "CP-717"), one of the peripheral units of CP-9200SH. The CP-717 operates on Windows95 and Windows NT4.0. Refer to the manuals for more details.

Refer to the manuals indicated below regarding matters that concern the CP-9200SH.

<Relevant documents>

Document No.	Name of document
KAE-C879-40	CP-9200SH Catalog
SIE-C877-17.4	CP-717 Operation Manual - Windows version (Vol.1)
SIE-C877-17.5	CP-717 Operation Manual - Windows version (Vol.2)
TOE-C877-17.7	CP-717 Instructions - Windows version
SIE-C879-40.1	CP-9200SH User's Manual
SIE-C879-40.2	CP-9200SH Servo Controller User's Manual
SIE-C879-40.3	CP-9200SH Programming Manual
SIE-C873-16.4	FDS System Installation Manual

- ◆ Windows 95 and Windows NT4.0 are trademarks of Microsoft corporation, USA.
- ◆ Ethernet is a registered trademark of Xerox USA Corp.





SAFETY PRECAUTIONS

- For correct use, be sure to read the Instruction and Maintenance Manual, this supplementary manual, and other attached documents thoroughly before use (installation, operation, maintenance, inspection, etc.). Also, be sure to use the equipment upon acquiring a thorough knowledge of the equipment, the safety information, and all of the precautions.

Be sure to store the documents at a place where they may be readily available for anyone using the device.

- "Safety Symbols" Used in this Manual

In this manual, the following symbols are used according to the descriptions on safety.

	WARNING	<input type="radio"/> Warning Indicates cases where erroneous handling may lead to a dangerous situation that accompanies the possibility of death or serious injury.
	CAUTION	<input type="radio"/> Caution Indicates cases where erroneous handling may lead to a dangerous situation that accompanies the possibility of medium or light injury or only material damage.
	MANDATORY	<input type="radio"/> Mandatory Indicates that grounding must be provided.
	PROHIBITED	<input type="radio"/> Prohibited Strong indication of a prohibited matter which may otherwise lead to serious results depending on the circumstances.

- In this manual, matters, that do not correspond to being a "WARNING " or a "CAUTION" should be adhered to by the user and are indicated next to the relevant items.

1 MOUNTING

 **WARNING**

- Be sure to perform mounting and dismounting work after turning OFF the power.
There is danger of electric shock, death, or serious injury if work is performed with the power ON.

 **CAUTION**

- Use the product in an environment described in the "CP-9200SH User's Manual."

Electric shock, fire, or malfunction may occur if the product is used in an environment with high temperature, high humidity, dust, corrosive gas, vibration, or shock.

Specifically, avoid use in the following environments.

- Places exposed to direct sunlight or places where the ambient temperature falls outside the range, 0 to +55°C.
 - Places where the relative humidity falls outside the range, 5 to 95%, and places where dew condensation may occur due to sudden changes in humidity.
 - Places with corrosive gas or flammable gas.
 - Places where vibration or shock may be transmitted directly to CP-9200SH.
 - Places where the product may get splashed with water, oil, chemicals, etc.
- The product should be mounted in accordance with the instructions described in the Instruction Manual.
Improper mounting may cause accidental fall, failure, or malfunction.

① Fasten mounting screws securely

Be sure to securely fasten the mounting screws for CP-9200SH and the fixing screws for terminal blocks so as not to allow them to loosen.

A loose screw may result in the malfunction of the CP-9200SH.

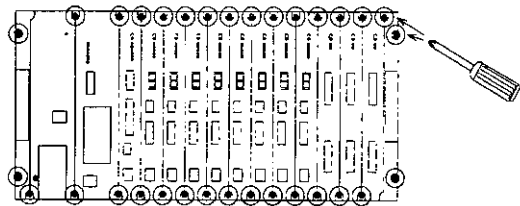

② Install the product correctly.

Incorrect installation may lead to abnormal heat generation and failure.

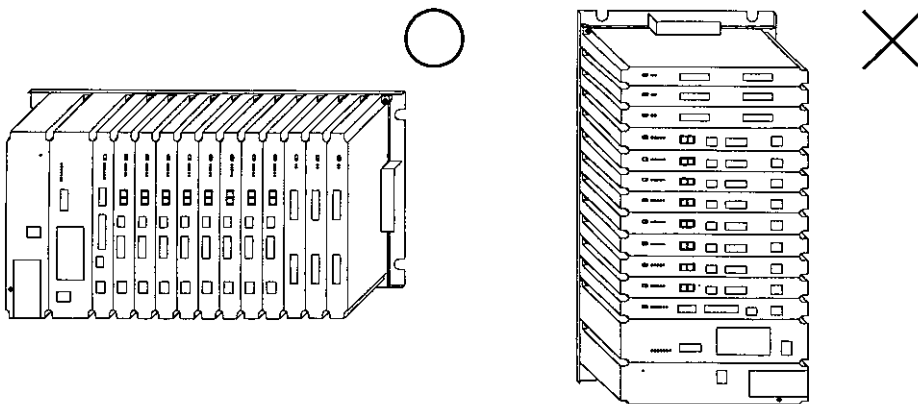

- Do not put foreign matters such as wire junks into the unit.

These may cause fire, failure, or malfunction.

2 WIRING

⚠ CAUTION

- Connect the power supply conforming to the rated power.

Connecting a power source not conforming to the rated power may cause fire.

For the PS-01 power supply 85 VAC to 132 VAC or 90 VDC to 140 VDC

For the PS-02 power supply 170 VAC to 230 VAC
--

For the PS-03 power supply 19.2 VDC to 28.2 VDC
--

- Only qualified personnel is allowed for wiring works with the manual.

Wrong wiring may cause electric shock, fire, or failure.

CONNECT THE INTERFACE SECURELY!

- Insert and fix the connectors of the various interface cables to be connected to CP-9200SH securely.

WHAT SHOULD BE DONE WHEN POWER SUPPLY IS UNSTABLE?

- When power supply is unstable, connect a line filter to the power supply line.

This will prevent malfunction of the CP-9200SH caused by noises.

When PS-01 is used.

PS-01 (100V AC, or 100V DC)

When PS-02 is used.

PS-02 (200V AC)

When PS-03 is used.

PS-03 (DC 24V)

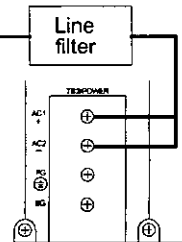

LAY THE EXTERNAL WIRING CORRECTLY.

- Select the I/O lines (external wiring) for connecting CP-9200SH with external equipment in consideration of following.

- | |
|--|
| <ul style="list-style-type: none"> • Mechanical strength • Influence of noise • Wiring distance • Signal voltage, etc. |
|--|

Lay and wire I/O lines apart from the power lines at the interior and exterior of the control panel.

This will help in reducing the influence of noise.

(Wire rack)

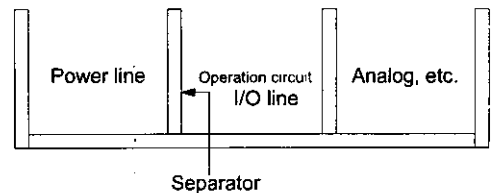

3 PRECAUTIONS UPON USE



WARNING

- Do not touch the terminals while the power is ON.
There is danger of electric shock.
- Provide an emergency stop circuit, interlock circuit, etc. at the exterior of CP-9200SH.

When it is anticipated that a failure of the CP-9200SH may cause operators to be hurt or products or peripheral units to be damaged, incorporate an emergency stop circuit or interlock circuit outside the CP-9200SH.

To start up the CP-9200SH by connecting a machine, make sure that the CP-9200SH can be stopped at any time for emergency.



CAUTION

- Changing the program, performing forced output, and performing operation such as RUN, STOP, etc. while CP-9200SH is running may cause program errors and operation errors which may lead to damage of the machine or to accidents.

Perform these upon adequate verification and with the utmost care.

4 MAINTENANCE AND DISPOSAL

WARNING

- Connect plus \oplus and minus \ominus poles of the battery correctly.
Do not charge, disassemble, heat up, throw into fire, or short-circuit the battery.
There is danger of explosion or firing.

CAUTION PROHIBITED

- Do not disassemble or modify.
There is danger of fire, failure, or malfunction.

CAUTION

- Handle the product as industrial waste upon disposal.

BE CAREFUL OF THE BATTERY LIFE.

- Be careful of the battery life.
Lighting of the Battery Alarm lamp tells the life end of the battery. Replace it for a new battery following the battery replacement procedure.

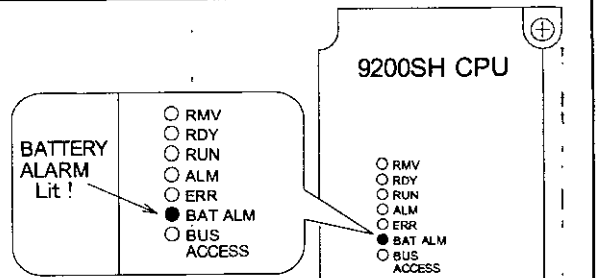

5 GENERAL PRECAUTIONS

PRECAUTIONS ON APPLICATION

- CP-9200SH is not designated or manufactured for use in devices or systems that concern people's lives.
Users who intend to use the product described in this manual for special purposes such as devices or systems relating to transportation, medical, space aviation, atomic power control, or underwater use must contact Yaskawa Electric Corporation beforehand.
- This product has been manufactured under strict quality control guidelines. However, if this product is to be installed in any location in which a failure of CP-9200SH involves a life and death situation or in a facility where failure may cause a serious accident, safety devices **MUST** be installed to minimize the likelihood of any accident.

Table of Contents

1	OUTLINE	1-1
1.1	System Configuration	1-2
1.2	How to Run PO-01 Module	1-6
1.2.1	Setting Module No.	1-10
1.2.2	Setting Motion Fixed Parameters	1-12
1.2.3	Setting Motion Set Parameters	1-13
1.2.4	Monitoring Running Status	1-14
1.3	Module No. and Motion Parameter Register No.	1-15
1.4	Command Pulse Forms and Maximum Frequency of Pulse Output	1-16
1.4.1	Command Pulse Forms	1-16
1.4.2	Maximum Frequency of Pulse output	1-16
1.5	Outline of Functions	1-18
1.5.1	Outline of Motion Commands	1-18
1.5.2	Types of Acceleration/Deceleration	1-18
1.6	Plug-in and -out of Hot Line	1-20
1.7	Precautions on Usage	1-21
2	BASIC SPECIFICATION	2-1
3	DESCRIPTION OF FUNCTION AND EXAMPLES OF USER PROGRAMS	3-1
3.1	Setting of Basic Motions Parameters	3-3
3.1.1	Command Units	3-3
3.1.2	Electronic Gears	3-3
3.1.3	Axis Selection	3-6
3.1.4	Position Commands	3-7
	(1) Position Commands	3-7
	(2) Position Monitoring	3-9
3.1.5	Speed Commands	3-10
3.2	Positioning (POSING)	3-13
3.3	Zero Point Return (ZRET)	3-16
3.3.1	DEC1 + ZERO Signal Method	3-18
3.3.2	DEC2 + ZERO Signal Method	3-18
3.3.3	DEC1 + LMT + ZERO Signal Method	3-20
3.4	Interpolation (INTERPOLATE)	3-26
3.5	Constant Speed Feed (FEED)	3-30
3.6	Constant Step Feed (STEP)	3-33
3.7	Zero Point Setting (ZSET)	3-37
3.8	Detection of Step-out	3-38
3.8.1	Outline	3-38
3.8.2	Examples of Application Programs	3-39
3.9	Emergency Stop	3-41
4	CONTROL BLOCK DIAGRAMS	4-1
5	MOTION PARAMETERS	5-1
5.1	List of Motion Parameters	5-2
5.1.1	List of Motion Fixed Parameters	5-2
5.1.2	List of Motion Set Parameters	5-5
5.1.3	List of Motion Monitor Parameters	5-9
5.2	Details of Motion Parameters	5-12
5.2.1	Details of Motion Fixed Parameters	5-12

5.2.2	Details of Motion Set Parameters	5-15
5.2.3	Details of Motion Monitor Parameters	5-21
5.3	Examples of Motion Parameter Setting.....	5-25
5.3.1	Examples of Motion Fixed Parameter Setting	5-25
5.3.2	Examples of Motion Set Parameter Setting	5-27

1 OUTLINE

This chapter describes the system configuration diagram, the operating method, and the outline of units. Be sure to read through this chapter because it provides the basis for using the module.

1.1 System Configuration

The CP-9200SH is an integrated controller provided with all general functions required for a machine controller.

Using user's programs allows users to freely design sequences suitable for machines or motion control.

The CP-9200SH consists of the following modules. Refer to the "CP-9200SH User's Manual" for details of each module.

Configuration of CP-9200SH

- **Power supply module**
Available for 24V, 100V, and 200V.
- **Mounting base**
Available are the short mounting base and the long mounting base.
Up to 4 mounting bases can be connected.
- **CPU Module**
Up to 2 CPU modules can be mounted. Each of them executes user's programs independently.
- **Motion modules**
There are two types of modules; an SVA module of analog output type and a PO-01 module of pulse-train output type (the current module). Up to 16 motion modules, including all types of motion modules, can be connected to a motion module.
The PO-01 module has such position control functions as positioning, zero point return, interpolation, constant speed feed, and constant step feed, and can be connected with a pulse motor driver of up to 4 axes. The PO-01 module can be mounted with up to 16 pieces (module No. 1 to 16), and can control up to 64 axes.
The SVA module has such functions as positioning, speed control, torque control, and phase control, and can be connected with a servo driver of up to 4 axes. And also it is provided with such functions as the reversible counter, interval counter, and frequency measurement unit so that it can be used as general-purpose counter module. The SVA module can be connected to up to 11 pieces (module No. 1 to 11), and can control up to 44 axes.
The SVB module has position control functions such as positioning, zero point return, interpolation, constant speed feed, and constant step feed, and can be connected with MECHATROLINK supported servo drivers and I/Os of up to 14 axes.
Up to 16 SVB modules (Module No. 1 to 16) can be mounted to control up to 224 axes.
The SVB module can be also connected to CP-216 supported inverters such as VS-616G5 and VS-676H5 using CP-216 transmission.
- **Communication module**
Various interface modules such as the CP-215 interface module, CP-216 interface module, and RS-232 interface module are available. The CP-717 is connected to the RS-232 interface module or CP-215 interface module.
- **I/O modules**
Can be connected with the local I/O and the 2000 series I/O modules.
- **Others**
Also available is a module for connecting between mounting bases.

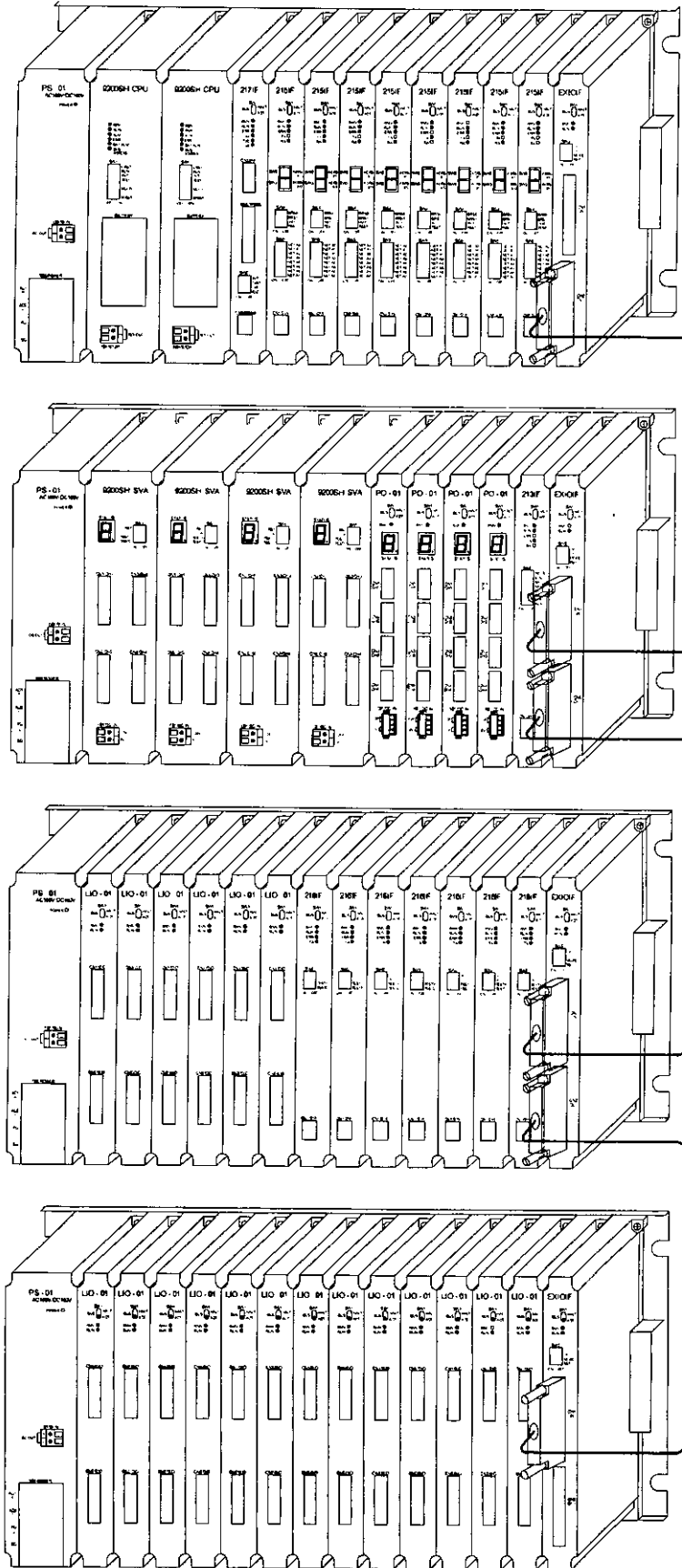

Fig. 1.1 CP-9200SH (Long mounting base)

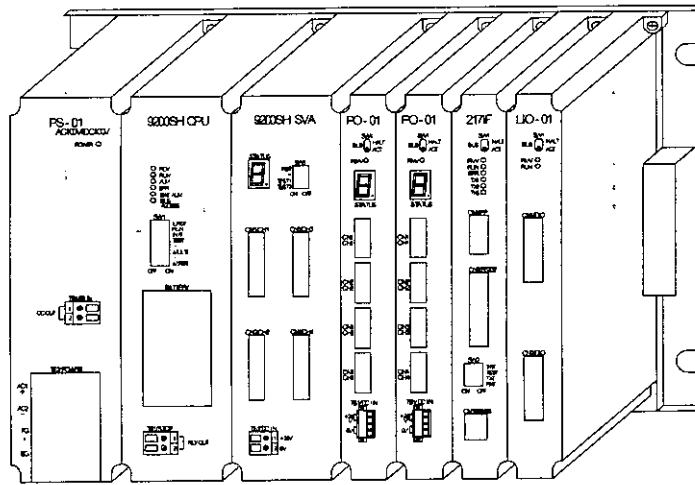

Fig. 1.2 CP-9200SH (Short mounting base)

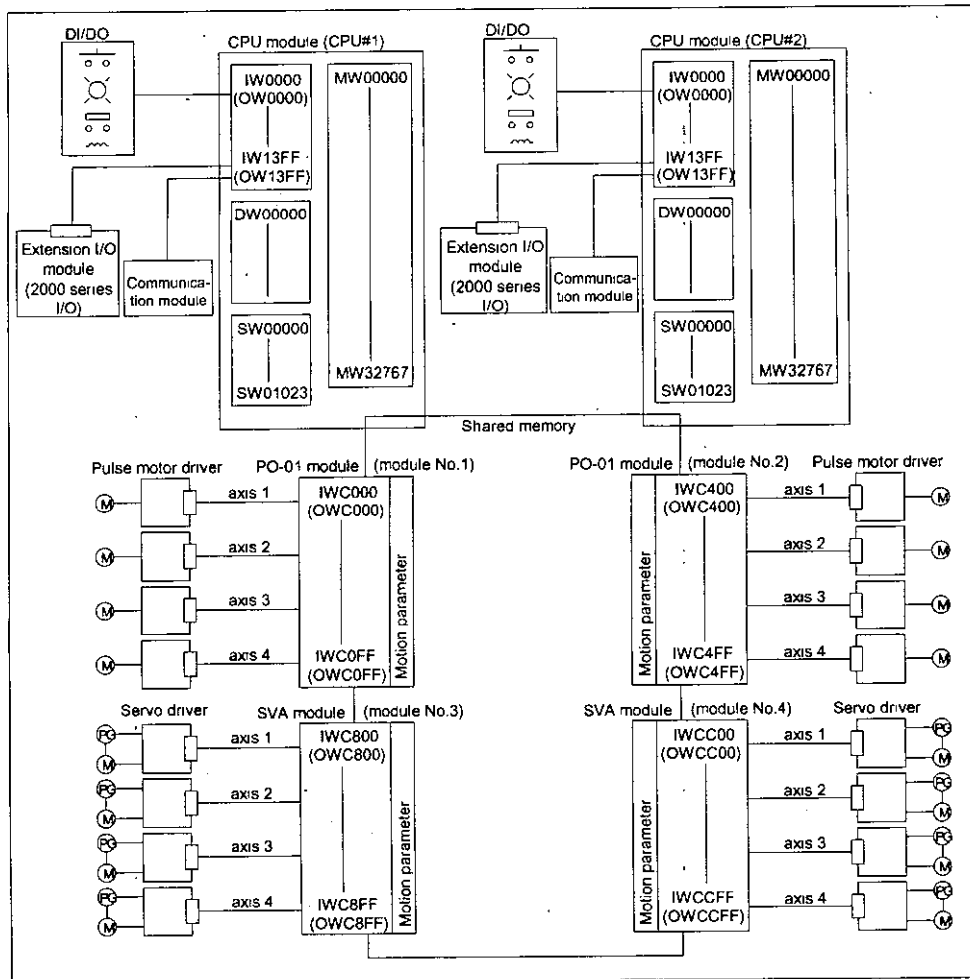

Fig. 1.3 Connection between CP-9200SH and its peripheral units (Software)

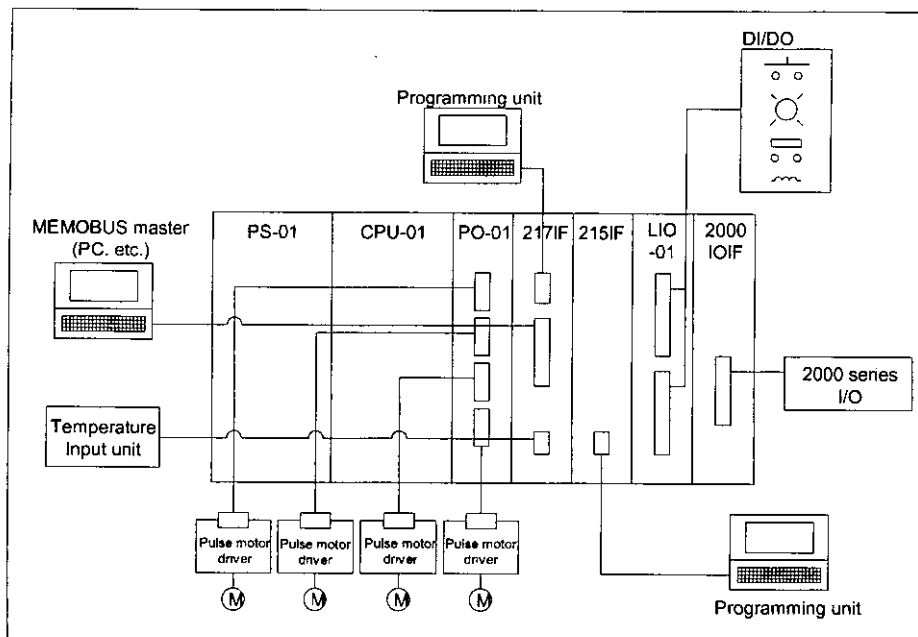

Fig. 1.4 Connection between CP-9200SH and its peripheral units (Hardware)

Table 1.1 List of Registers

Register Type	Description
SW (System register)	Holds the operating status of the system or error information.
IW (Input register)	The I/O register directly connected to the hardware accessible to the CPU module such as DI/DO and 2000 series I/O, and the CP-215 or CP217 which is accessible by the transmission route.
OW (Output register)	Hardware and I/O registers are allocated at the CP-717 Module Configuration Definition Window. IW(OW)C000 to IW(OW)FFFF are used for transferring motion parameters. Accessible to both CPU#1 and CPU#2.
MW (DWG common register)	The general-purpose register common to each DWG. Used for transferring data between DWGs. Transferring data between CPUs is also allowed by defining a part of this register at CP-717. Refer to the "Shared Memory Allocation Window" of CP-717.
DW (DWG individual register)	The general-purpose register individual to each DWG. Therefore, one DWG register cannot refer to other DWG register. Using this register will make it simple to package software.

1.2 How to Run PO-01 Module

First, allocate a module No. to the PO-01 module. Setting motion parameters after this will allow motion control to be performed. Designing these motion parameters freely by user's programs provides motion control suitable for machines.

■ Allocating module Nos.

Perform the allocation at the "Module Configuration Definition Window" of CP-717.

■ Data transfer between CPU module and PO-01 module

Data are transferred via the motion parameter. The motion parameter is divided into the following three types.

(1) Motion fixed parameter

A parameter which will, once set, normally be never changed as long as the configuration or specification of a machine is not changed. Set it with the "Fixed parameter" tab of the motion CP-717. Changing the motion fixed parameter will result in initializing the motion monitor parameter such as the calculated position of the machine coordinate system.

(2) Motion set parameter

This parameter is used for commanding the PO-01 module by the CPU module. At the beginning of high-speed scan, the parameter is transferred to the PO-01 in a batch. Motion control can be performed only by setting this motion parameter.

(3) Motion monitor parameter

This parameter is used for reporting from the motion module to the CPU module. At the beginning of high-speed scan, the parameter is transferred to the CPU module in a batch. This parameter is also applied for application control and debugging user's programs.

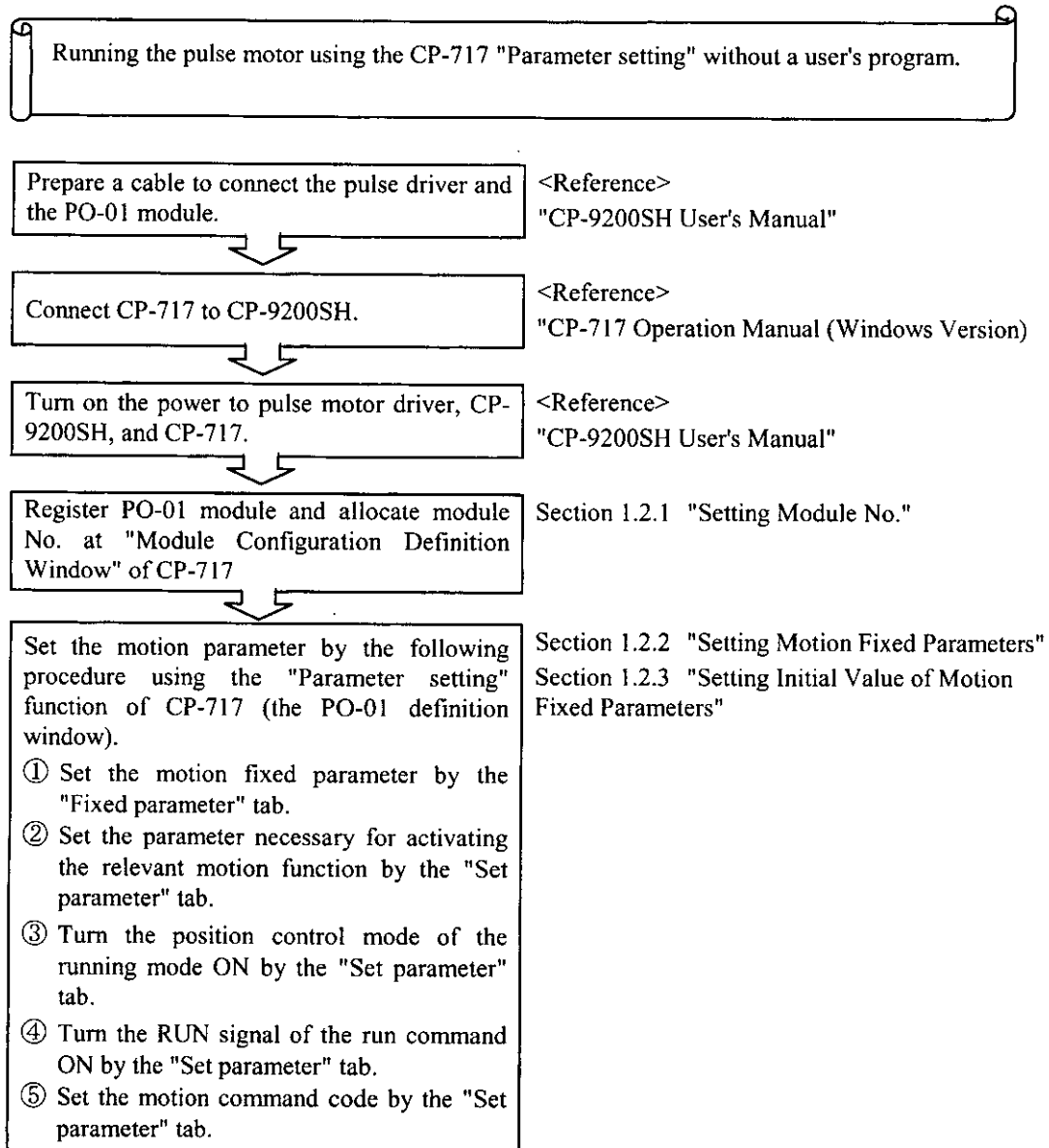

Fig. 1.5 Pulse Motor Operating Procedure

Now, let's prepare a simple user's program. Here is an example of the constant speed feed which is the simplest one for checking the operation of the pulse motor.

Using the user's program, set the motion parameters which have been set by the "Parameter setting" function at the "Pulse Motor Operating Procedure" in Fig.1.5

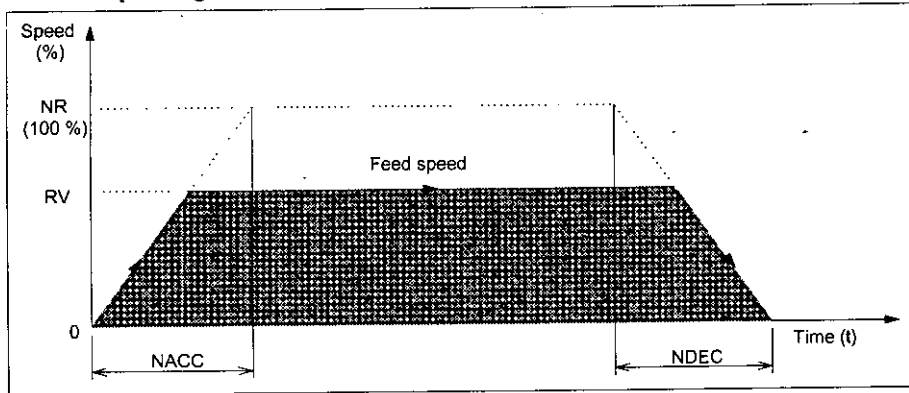

Fig.1.6 An example of Constant Step Feed

<Preconditions>

Motor rated revolution speed : NR=400r/min
 Command unit : in the unit of pulses
 The number of pulses per one revolution of motor : 2000 pulses
 Maximum frequency of pulse output : 100 kHz
 Set the parameters mentioned above by the "Fixed parameter" tab of CP-717.

<Operation Conditions>

Running mode : Position control mode
 Linear acceleration time : NACC=0.5 seconds
 Linear deceleration time : NDEC=0.5 seconds
 Motion command code : constant speed feed
 Rapid feed speed : 400000 pulses/min

Under the conditions mentioned above, the first axis of module No.1 is used.

For example, Fig. 1.7 shows Fig.1.6 expressed in the programming language. Refer to Chapter 5, "Motion Parameter" for the register (OWxxxx) to be used.

└ 500	NACC ⇒ 0WC00C	Linear acceleration time constant (NACC)
	NDEC ⇒ 0WC00D	Linear deceleration time constant (NDEC)
	RUNMOD ⇒ 0WC000	Setting of running mode (RUNMOD) (Position control mode selection)
└ 4 DEND		

Fig.1.7 Initial Setting (DWG A01)

Although the user's program is prepared at DWG.A for initial setting in the example of Fig.1.7, the initial values of the motion set parameters can be saved by "saving" after having set the initial values by the "Set parameter" tab of CP-717. The saved initial values are automatically set to the motion parameters when the power of CP-9200SH is turned on. Therefore, this is equivalent to the method by which the user's program is prepared at DWG.A for initial setting. Considering the easiness of initial setting, the method by which the initial values are set by the "Set parameter" tab and then saved is recommended.

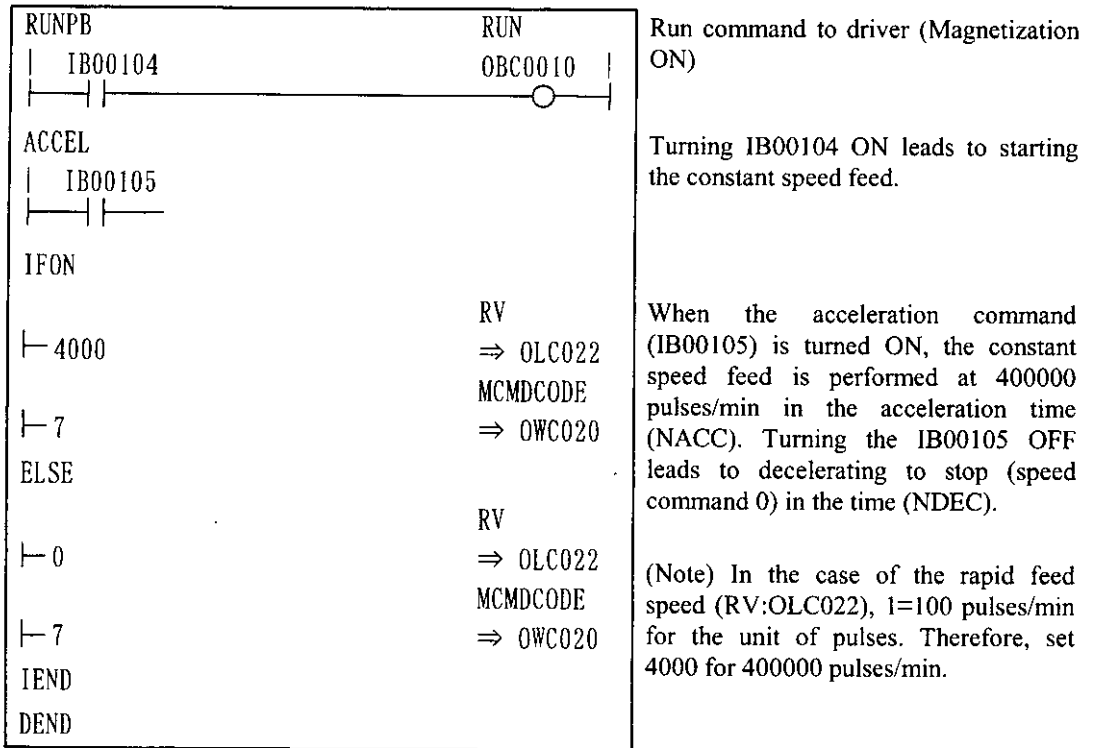

Fig. 1.8 Constant-speed Feed Command (DWG H01)

The example in Fig.1.8 has been simplified, however, each register, etc., can be freely controlled by the user's program.

1.2.1 Setting Module No.

Set the module No. at the "Module Configuration Definition Window" of CP-717. The setting procedure is as follows. Refer to the "CP-717 Operation Manual (Windows Version)" for more details.

- ① Register the PO-01 to the slot where the PO-01 module is mounted.
- ② Set the module No. at the "Cir No." column.
- ③ The above procedures has brought an end to the module No. setting. Completing the setting will allow the range of the register (IW/OW) for the motion parameter to automatically appear at the "Register range" column.
- ④ Save the No.
- ⑤ Turn ON/OFF the power of the CP-9200SH, or turn ON → OFF the master reset of the CPU module.
- ⑥ The module No. is displayed on the LED of the PO-01 module.

Configuration elements of the "Module Configuration Definition" window

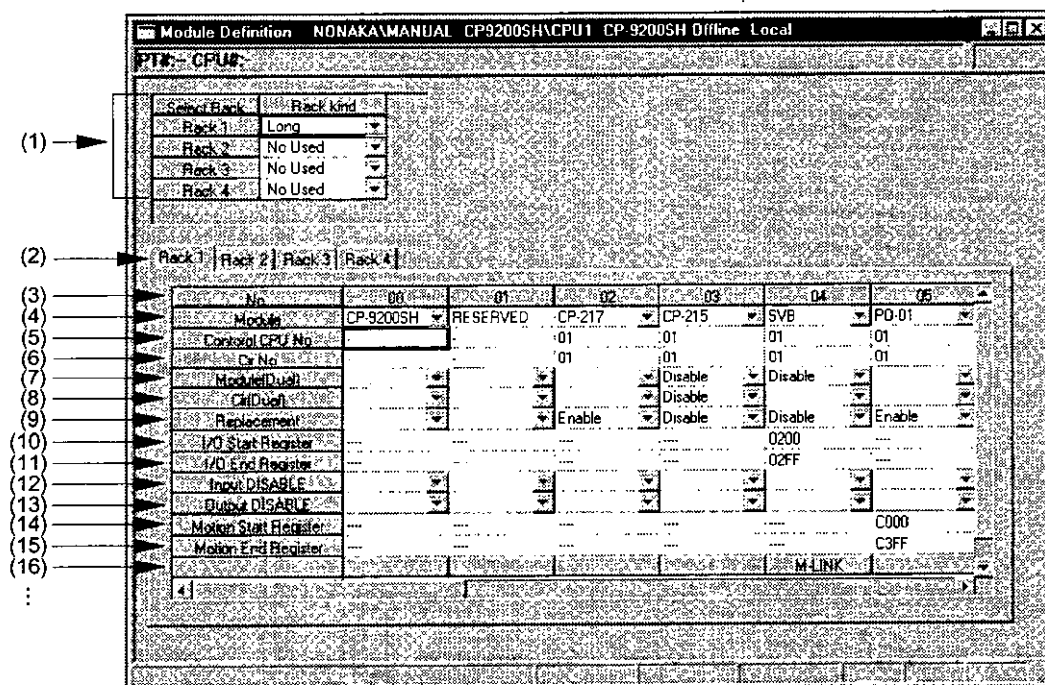

- (1) Configuration rack information
Select the configuration of the rack to be connected by the module.
- (2) Rack No. selection
Select the rack No. to which the module is defined.
- (3) No.
Displays the slot No. on which the module is mounted.
- (4) Module
Select "PO-01" for the module to be mounted to each slot.
- (5) Control CPU No.
Enter "01(CPU#1)" to the CPU No. which controls each module.
- (6) Cir No.
Enter the line No. of each module. For PO-01 modules, enter the module No. (1 to 16) here.

- (7) Module [Dual]
Designate the dualization of modules. For PO-01 modules, setting is not necessary.
- (8) Cir [Dual]
Set the dualization of the transmission line of CP-215. For PO-01 modules, setting is not necessary.
- (9) Replacement
Designate "Enable/Disable", for plug-in/out of the hot line of each module. To allow the plug-in/out of the hot line, set to "Enable."
- (10) I/O start register
Input the I/O start register No. of each module. For PO-01 modules, setting is not necessary.
- (11) I/O end register
Input the I/O end register No. of each module. For PO-01 modules, setting is not necessary.
- (12) Input DISABLE
Set the input DISABLE of each module. For PO-01 modules, setting is not necessary.
- (13) Output DISABLE
Set the output DISABLE of each module. For PO-01 modules, setting is not necessary.
- (14) Motion start register
Input the I/O start register No. of motion module.
- (15) Motion end register
Input the I/O end register No. of motion module.
- (16) Detail
The presence of setting in detail for a module will cause M-LINK to appear. For PO-01 modules, setting is not necessary.
- (17) Status
The status of each module in the on-line mode. Nothing is displayed in the off-line mode.

1.2.2 Setting Motion Fixed Parameters

Set required fixed parameters by the "Fixed parameter" tab at the CP-717:PO-01 Definition Window. Refer to the "CP-717 Operation Manual (Windows Version)" for more details.

Configuration elements of "Fixed parameter" tab

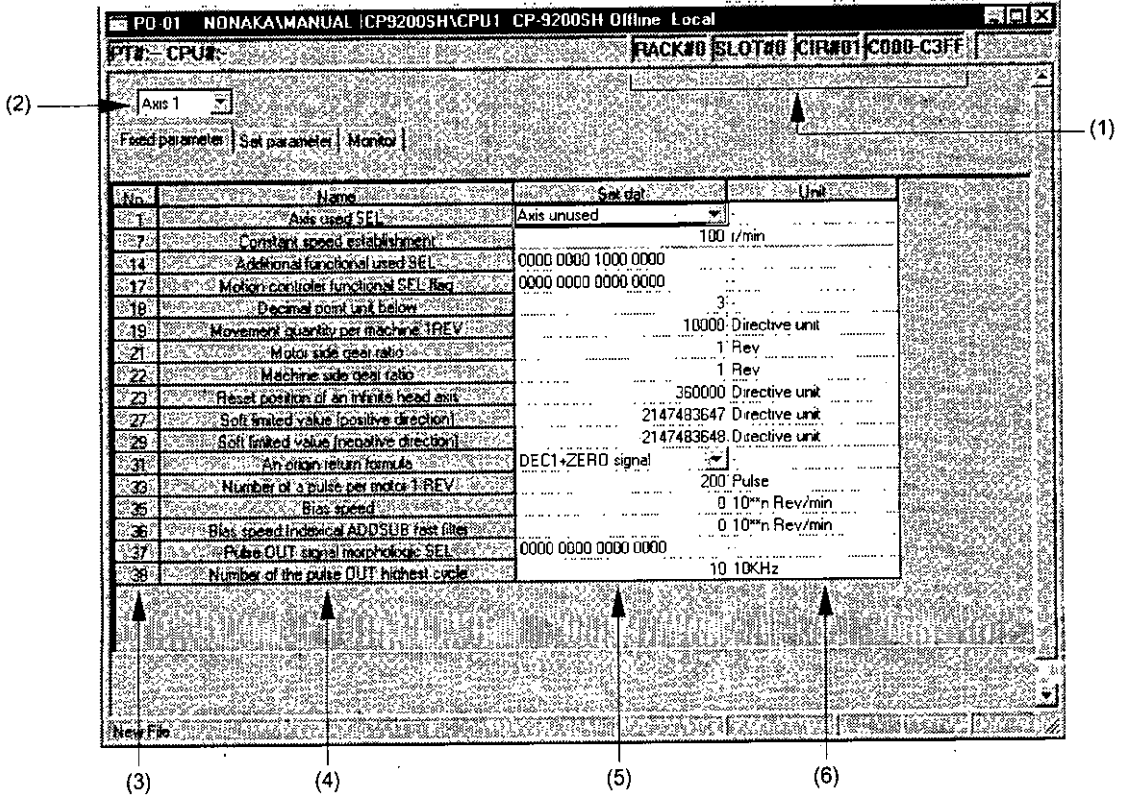

(1) Configuration information

The configuration information of the PO-01 module is displayed.

(2) Axis No.

Select the axis No. from axis 1 to axis 4. Set the fixed parameter for each axis.

(3) No.

The parameter No. of the fixed parameter is displayed.

(4) Name

The name of the parameter is displayed.

(5) Set dat

Input (select) the parameter value.

(6) Unit

The unit of the parameter is displayed.

Note

The motion fixed parameter cannot be stored when the current value of magnetization ON (bit 0) is ON at No.2 "Run command setting (OWxx01)" of the motion parameter for setting.

1.2.3 Setting Motion Set Parameters

Set required parameters by the "Set parameter" tab at the CP-717:PO-01 Definition Window. The data set here are to be automatically set to the initial values of motion set parameters at the time of turning on the power of the CP-9200SH. Refer to the "CP-717 Operation Manual (Windows Version)" for more details.

Configuration elements of "Set parameter" tab

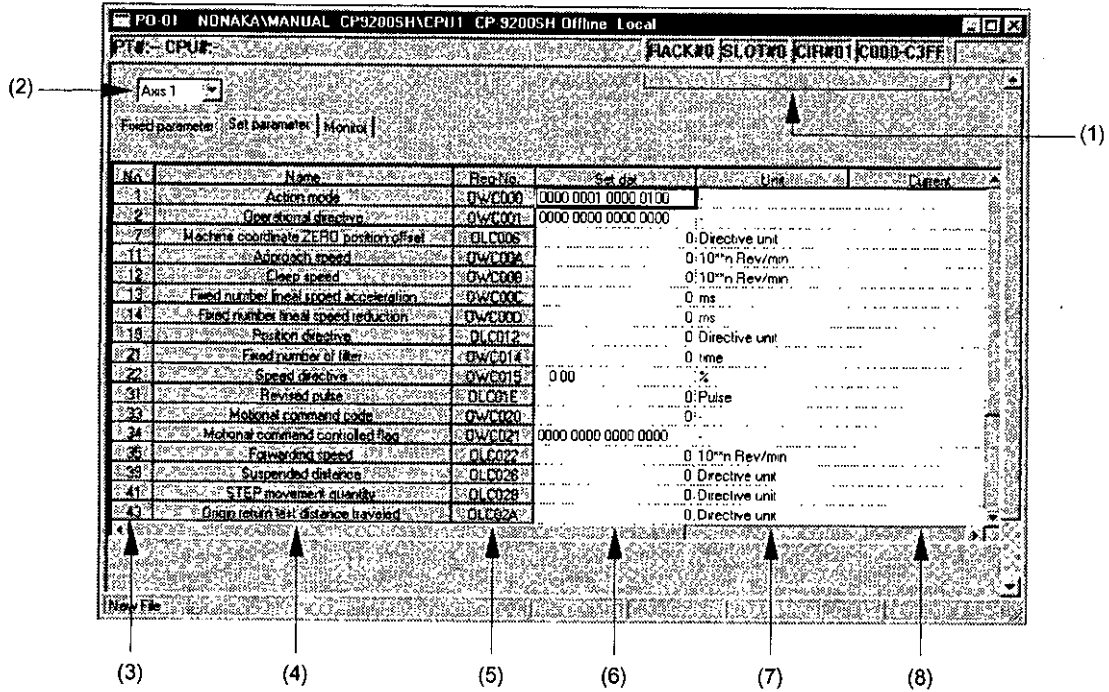

- (1) Configuration information
The configuration information of the PO-01 module is displayed.
- (2) Axis No.
Select the axis No. from axis 1 to axis 4. Set a set parameter for each axis.
- (3) No.
The parameter No. of the set parameter is displayed.
- (4) Name
The name of the parameter is displayed.
- (5) Reg-No.
The register No. corresponding to the parameter name is displayed. The range of a register is different according to the currently displayed module No. and axis No.
- (6) Set dat
Input the parameter value.
- (7) Unit
The unit of the parameter is displayed.
- (8) Current
The current value of a parameter is displayed in the on-line mode. Nothing is displayed in the off-line mode.

1.2.4 Monitoring Running Status

Motion monitor parameters are displayed at the "CP-717:PO-01 Definition Window." The window is available for debugging user's programs or tuning the motion control.

This window displays only the current value of the motion monitor parameter and is not available for input.

Configuration Elements of the "Motion Monitor" tab

No.	Name	Reg.No.	Monitor dat	Unit
1	Operational status	IWC000		
2	Wide use DI monitor	IWC001		
3	Machine coordinate system position	ILC002		Directive unit
5	Increase minute monitor of goal position	ILC004		Directive unit
16	Scope over original parameter No.	IWC008		
21	Motional command response code	IWC014		
22	Motional command status	IWC015		
23	Decimal point of unit monitor below	IWC016		
24	Position management status	IWC017		
25	Machine coordinate directive position	ILC018		Directive unit
28	POS MAX monitor	ILC01C		Directive unit
31	Number of POS MAX turn	ILC01E		Rev
35	Alarm	ILC022		
39	Speed directive OUII worth monitor	ILC028		Rev/H Scan
41	Read data Position buffer	ILC028		
43	Number of an OUII pulse	ILC02A		Pulse
47	Directive coordinate calculative position	ILC02E		Directive unit

(1) Configuration Information

The configuration information of the PO-01 module is displayed.

(2) Axis No.

Select an axis No. from axes 1 to axis 4. The motion monitor parameter is displayed for each axis.

(3) No.

The parameter No. of a monitor parameter is displayed.

(4) Name

The parameter name is displayed.

(5) Reg-No.

The register No. corresponding to the parameter name is displayed. The range of a register is different according to the currently displayed module No. and axis No.

(6) Monitor dat

The current value of a parameter is displayed in the on-line mode. Nothing is displayed in the off-line mode.

(7) Unit

The unit of a parameter is displayed.

1.3 Module No. and Motion Parameter Register No.

The motion parameter register No. (I or O register No.) is different according to the module No. and axis No. (1 through 4).

The motion parameter register No. is given by the following equation.

$$\text{Motion register No. (IWxxxx and OWxxxx)} = \text{Module No. offset} + \text{Axis offset}$$

The module No. offset is as shown below according to the module No.

Module No.1 = C000,	Module No.2 = C400,	Module No.3 = C800,	Module No.4 = CC00,
Module No.5 = D000,	Module No.6 = D400,	Module No.7 = D800,	Module No.8 = DC00,
Module No.9 = E000,	Module No.10 = E400,	Module No.11 = E800,	Module No.12 = EC00,
Module No.13 = F000,	Module No.14 = F400,	Module No.15 = F800,	Module No.16 = FC00,

The axis offset is as shown below according to each axis No.

$$\text{Axis offset} = (\text{Axis No.} - 1) \times 40\text{H}(64 \text{ words})$$

The contents described above are summarized in Table 1.2.

Table 1.2 Motion Parameter Register No.

Module No.	IW(OW) of axis 1	IW(OW) of axis 2	IW(OW) of axis 3	IW(OW) of axis 4
1	C000 to C03F	C040 to C07F	C080 to C0BF	C0C0 to C0FF
2	C400 to C43F	C440 to C47F	C480 to C4BF	C4C0 to C4FF
3	C800 to C83F	C840 to C87F	C880 to C8BF	C8C0 to C8FF
4	CC00 to CC3F	CC40 to CC7F	CC80 to CCBF	CCC0 to CCFE
5	D000 to D03F	D040 to D07F	D080 to D0BF	D0C0 to D0FF
6	D400 to D43F	D440 to D47F	D480 to D4BF	D4C0 to D4FF
7	D800 to D83F	D840 to D87F	D880 to D8BF	D8C0 to D8FF
8	DC00 to DC3F	DC40 to DC7F	DC80 to DCBF	DCC0 to DCFE
9	E000 to E03F	E040 to E07F	E080 to E0BF	E0C0 to E0FF
10	E400 to E43F	E440 to E47F	E480 to E4BF	E4C0 to E4FF
11	E800 to E83F	E840 to E87F	E880 to E8BF	E8C0 to E8FF
12	EC00 to EC3F	EC40 to EC7F	EC80 to ECBF	ECC0 to ECFE
13	F000 to F03F	F040 to F07F	F080 to F0BF	F0C0 to F0FF
14	F400 to F43F	F440 to F47F	F480 to F4BF	F4C0 to F4FF
15	F800 to F83F	F840 to F87F	F880 to F8BF	F8C0 to F8FF
16	FC00 to FC3F	FC40 to FC7F	FC80 to FCBF	FCC0 to FCFF

Note

Motion register Nos. are inconsecutive for registers with different module Nos. Register Nos. between axes are consecutive when their module Nos. are the same. Care should be taken when a subscript (i,j) is used in the user's program.

(Example)

For IW(OW)C000i , reading is performed without any error for $i=0$ up to 255.

For IW(OW)C000 , the register range of module No.1, that is, the range from IW(OW)C000 to IW(OW)C0FF , can be read and written without any error. However, reading cannot be performed for $i \geq 256$.

1.4 Command Pulse Forms and Maximum Frequency of Pulse Output

1.4.1 Command Pulse Forms

The format of the command pulse is divided into two types; the sign scheme (sign + pulse train) and the CW/CCW scheme. Both schemes are of the differential output at 5V.

- Sign scheme

The CW pulse is the command pulse.

The CCW pulse is the sign.

The motor revolves in the forward direction when the CCW pulse is "High", and in the reverse direction when it is "Low."

- CW/CCW scheme

The CW pulse is the reverse revolution command pulse for the motor.

The CCW pulse is the forward revolution command pulse for the motor.

The polarity of CW/CCW output signal can be selected. The format of the command pulse is shown in Table 1.3.

Table 1.3. Format of Command Pulses

Motion fixed parameter (Parameter No. = 37) (Pulse output signal format selection)		Command pulse format	Motor forward revolution command (counter-clockwise direction)	Motor reverse revolution command (clockwise direction)
Bit 8	Bit 12 to 15			
0 (Positive logic)	0	Sign + pulse train		
	1	CW pulse + CCW pulse		
1 (Negative logic)	0	Sign + pulse train		
	1	CW pulse + CCW pulse		

1.4.2 Maximum Frequency of Pulse Output

The command pulse available for output by the PO-01 module is determined by the high-speed scan time to be set to the CPU module and the maximum frequency of the pulse output to be set to the motion fixed parameter.

$$0 \leq | \text{Command pulse (kpps)} | \leq \{ \text{MAXHz}(10\text{kHz}) \times 10 \times T_s(\text{ms}) - 2 \} / T_s(\text{ms})$$

MAXHz : Fixed parameter No.38 "Pulse output maximum frequency" (unit: 10 kHz)
 T_s : High-speed scan time of the CPU module (unit: ms)

(Example)

1) When T_s=1 (1.0 ms), Pulse output maximum frequency = 10 (100 kHz);
 Maximum command pulse = $(10 \times 10 \times 1.0 - 2) / 1.0$
 = 98.0(kpps)

2) When T_s=2 (2.0 ms), Pulse output maximum frequency = 20 (200 kHz);
 Maximum command pulse = $(20 \times 10 \times 2.0 - 2) / 2.0$
 = 199.0(kpps)

Setting a feed speed (command pulse) more than the above maximum command pulse will cause an alarm, "The excessive speed (IBxx227)", to be turned ON and stop.

Notes

1. The pulse output maximum frequency is common to 4 axes. Set the same value also for unused axes. If different values are set, the value set for the smallest axis number among the axes to be used is taken into effect.

(Example)	In use/Not in Use	Maximum Frequency
Axis 1	Not in use	100 kHz
Axis 2	In use	10 kHz
Axis 3	In use	20 kHz
Axis 4	Not in use	40 kHz

In the above example, 10 kHz of Axis 2 is set in common to 4 axes.

Changing the status of Axis 1 to "In use" in the above example changes the value common to 4 axes to 100 kHz of Axis 1. Changing the status of Axis 2 to "Not in use" in the above example, changes the value common to 4 axes to 20 kHz of Axis 3.

2. Set a value for the pulse output maximum frequency so that the result of "200 / Pulse Output Maximum Frequency (1 = 10 kHz)" is an integer: Set one of 1 (10 kHz), 2 (20 kHz), 4 (40 kHz), 5 (50 kHz), 8 (80 kHz), 10 (100 kHz), 20 (200 kHz), 25 (250 kHz), 40 (400 kHz), 50 (500 kHz).

1.5 Outline of Functions

1.5.1 Outline of Motion Commands

The PO-01 module is provided with such motion commands as the positioning (POSING), zero point return (ZRET), interpolation (INTERPOLATE), constant speed feed (FEED), and constant step feed (STEP) which can be independently selected for each axis.

Table 1.4 List of Functions of PO-01

Function	Description
Positioning (POSING)	Positioning is performed at the position for positioning with the designated acceleration/deceleration time constant and designated feed speed.
Zero point return (ZRET)	Positioning is performed by moving the distance to return to the origin from the origin signal. The method for returning to origin is divided into four types.
Interpolation (INTERPOLATE)	Feed is performed by interpolation according to the position data given by the CPU module for every high-speed scan.
Constant speed feed (FEED)	Rapid feed is performed in the designated direction at the designated acceleration/deceleration time constant and the designated feed speed toward an infinite point. Use the NOP command for a stop by deceleration.
Constant step feed (STEP)	Positioning is performed in the designated direction by the designated distance of movement (STEP amount of movement) at the designated rapid speed with the designated acceleration/deceleration time constant.

1.5.2 Types of Acceleration/Deceleration

Types of acceleration/deceleration are largely divided into the linear acceleration/deceleration, the S-curve acceleration/deceleration, and exponential acceleration/deceleration. Setting of bias speed is available for the linear acceleration/deceleration and the exponential acceleration/deceleration.

Table 1.5 Types of Acceleration/Deceleration

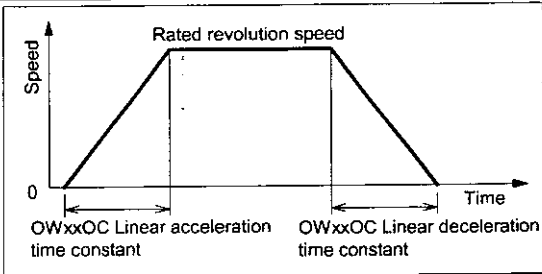
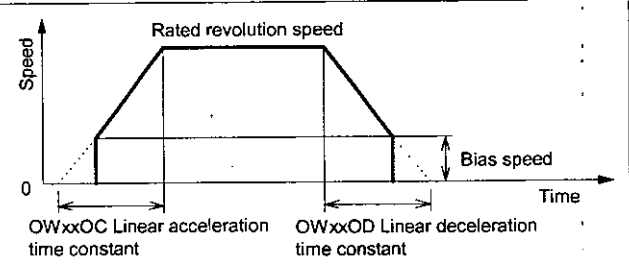
Types of acceleration/deceleration	Relevant motion parameter	Description
Linear acceleration/deceleration	Bias speed (Motion fixed parameter No.35) OWxx0C (Motion set parameter) "Linear acceleration time constant" OWxx0D (Motion set parameter) "Linear deceleration time constant"	 <p>Set the duration of time to reach the rated revolution speed to the acceleration/deceleration time constant. Set "0" to the motion fixed parameter No.35, "Bias speed."</p>
Biased linear acceleration/deceleration	Bias speed (Motion fixed parameter No.35) OWxx0C (Motion set parameter) "Linear acceleration time constant" OWxx0D (Motion set parameter) "Linear deceleration time constant"	 <p>Set the duration of time to reach the rated revolution speed to the acceleration/deceleration time constant.</p>

(to be continued)

Table 1.5 Types of Acceleration/Deceleration

(continued)

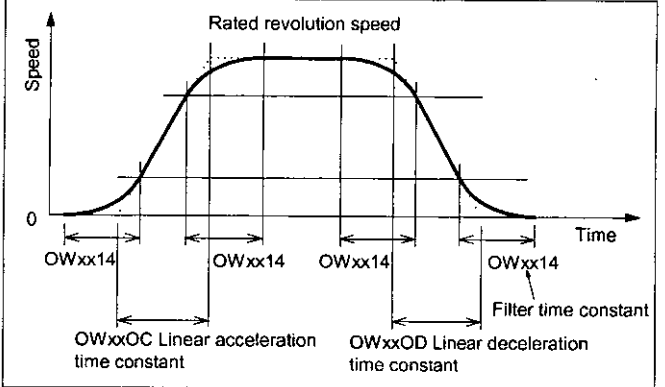
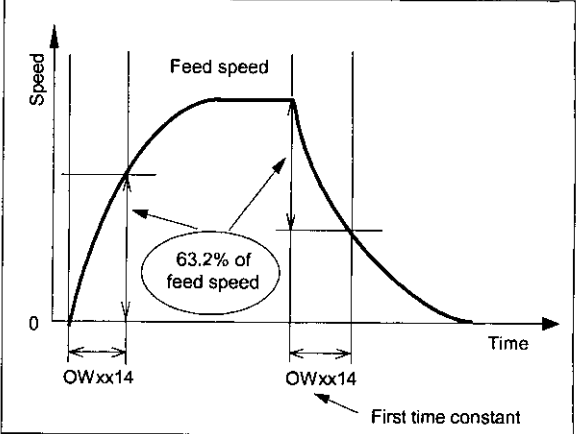
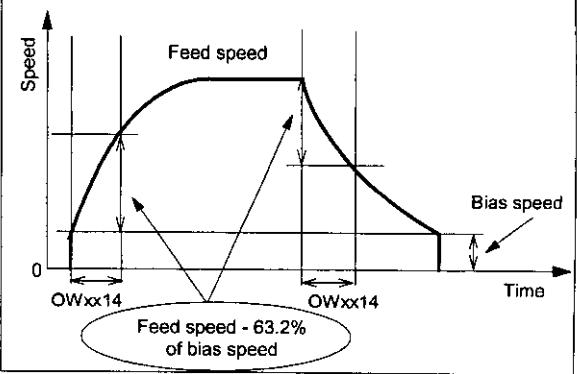
Types of acceleration/deceleration	Relevant motion parameter	Description
<p>S-curve acceleration/deceleration (Moving average)</p>	<p>OWxx0C (Motion set parameter "Linear acceleration time constant")</p> <p>OWxx0D (Motion set parameter "Linear deceleration time constant")</p> <p>OWxx14 (Motion set parameter "filter time constant")</p> <p>OBxx214 to OBxx217 (Motion set parameter "filter type selection")</p>	 <p>Rated revolution speed</p> <p>Speed</p> <p>Time</p> <p>0</p> <p>OWxx14</p> <p>OWxx14</p> <p>OWxx14</p> <p>OWxx14</p> <p>Filter time constant</p> <p>OWxx0C Linear acceleration time constant</p> <p>OWxx0D Linear deceleration time constant</p> <p>Set "2" (the moving average filter) to the filter type selection.</p>
<p>Exponential acceleration/deceleration</p>	<p>OWxx0C (Motion set parameter "Linear acceleration time constant")</p> <p>OWxx0D (Motion set parameter "Linear deceleration time constant")</p> <p>OWxx14 (Motion set parameter "filter time constant")</p> <p>OBxx214 to OBxx217 (Motion set parameter "filter type selection")</p> <p>Bias speed for exponential acceleration/deceleration filter (Motion fixed parameter No.36)</p>	 <p>Feed speed</p> <p>Speed</p> <p>Time</p> <p>0</p> <p>OWxx14</p> <p>OWxx14</p> <p>63.2% of feed speed</p> <p>First time constant</p> <ul style="list-style-type: none"> • Set "0" to the linear acceleration/deceleration time constant (OWxx0C and OWxx0D). • Set "1" (Exponential acceleration/deceleration) to the filter type selection. • Set "0" to the bias speed for the exponential acceleration/deceleration filter.
<p>Biased exponential acceleration/deceleration</p>	<p>OWxx0C (Motion set parameter "Linear acceleration time constant")</p> <p>OWxx0D (Motion set parameter "Linear deceleration time constant")</p> <p>OWxx14 (Motion set parameter "filter time constant")</p> <p>OBxx214 to OBxx217 (Motion set parameter "filter type selection")</p> <p>Bias speed for exponential acceleration/deceleration filter (Motion fixed parameter No.36)</p>	 <p>Feed speed</p> <p>Speed</p> <p>Time</p> <p>0</p> <p>OWxx14</p> <p>OWxx14</p> <p>Feed speed - 63.2% of bias speed</p> <p>Bias speed</p> <ul style="list-style-type: none"> • Set "0" to the linear acceleration/deceleration time constant (OWxx0C and OWxx0D). • Set "1" (Exponential acceleration/deceleration) to the filter type selection.

1.6 Plug-in and -out of Hot Line

The PO-01 module is intended to allow the plug-in and -out (to replace the module with the power ON). It is necessary to suspend the data updating operation between the CPU module and the module to be replaced when the module is replaced because the CPU module is always updating the data between mounted modules. The hot line cannot be plugged in or out when the magnetization is ON (the motion set parameter, "OBxx010" is ON). To assure safety, turn off the power to replace a module.

The method of plug-in and -out of hot line (PO-01 module)

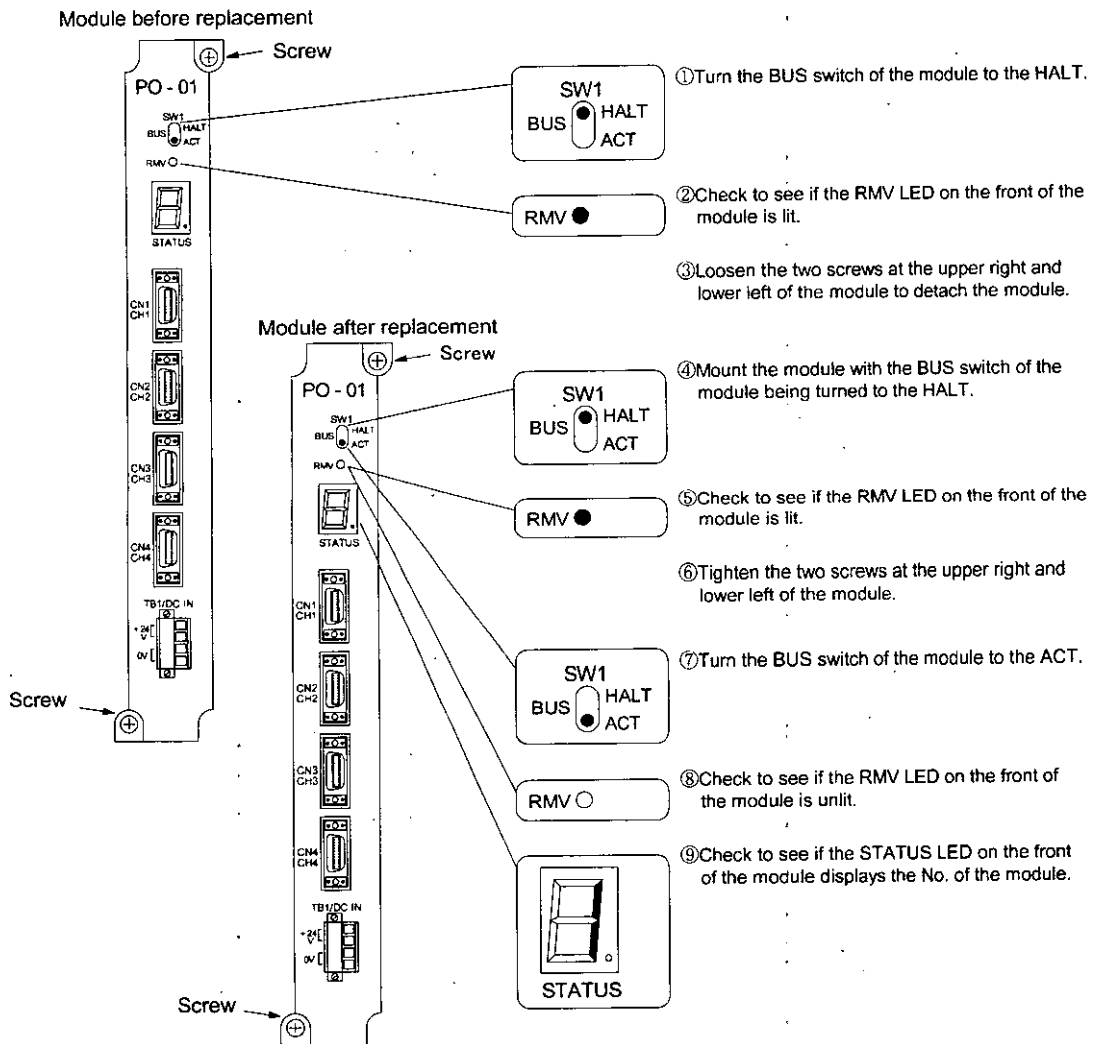

Note

For plug-in and -out, make sure to turn the BUS switch to the HALT of the module to be replaced to see if the RMV LED is lit and then remove the module from the mother board.

When the RMV LED is lit, the CPU module is updating data between each module. For this reason, removing the module when the RMV LED is not lit may result in an error with the data updating of another module, causing a system operation error.

1.7 Precautions on Usage

Pay attention to the following points when using the PO-01 module.

- (1) Set the high-speed scan set time for the CPU module to 150 ms or less. The minimum value of the high-speed scan set time is as mentioned below.

Set it so as to exceed the minimum value. The guideline of the setting is 1.5 ms to 150 ms.

- ① For the axis selection (Bit 5 of the fixed parameter No.17, "Motion controller function selection flag") = Finite-length axis ("0")

$$\text{The minimum value of the high-speed scan set value} = 400 \mu\text{s} + (150 \mu\text{s} \times \text{the number of axes in use})$$

↑
Common to the finite-length axis/infinite-length axis

- ② For the axis selection (Bit 5 of the fixed parameter No.17, "Motion controller function selection flag") = Infinite-length axis ("1")

$$\text{The minimum value of the high-speed scan set value} = 400 \mu\text{s} + (200 \mu\text{s} \times \text{the number of axes in use})$$

↑
Common to the finite-length axis/infinite-length axis

(Example)

- ① When the 4 axes are set to the finite-length axis;

$$\text{The minimum value of the high-speed scan set value} = 400 \mu\text{s} + 150 \mu\text{s} \times 4 = 1000 \mu\text{s} (= 1.0 \text{ ms})$$

- ② When the 4 axes are set to the infinite-length axis;

$$\text{The minimum value of the high-speed scan set value} = 400 \mu\text{s} + 200 \mu\text{s} \times 4 = 1200 \mu\text{s} (= 1.2 \text{ ms})$$

- ③ When every 2 axes are set to the finite-length axis and the infinite-length axis respectively;

$$\text{The minimum value of the high-speed scan set value} = 400 \mu\text{s} + 150 \mu\text{s} \times 2 + 200 \mu\text{s} \times 2 = 1100 \mu\text{s} (= 1.1 \text{ ms})$$

- (2) Do not change the high-speed scan setting of the CPU module during movement (positioning and when the motion command such as zero point return is being issued).
- (3) Make sure to turn the power on and then off when the module configuration definition of the CPU module has been changed.

2 BASIC SPECIFICATIONS

 This chapter describes basic specifications of the PO-01 module, including hardware and software.

The PO-01 module is available for motion control for up to 4 axes per one module. The PO-01 module has such motion control functions as positioning, zero point return, interpolation, constant speed feed, and constant step feed, which can be selected by each axis independently. Motion control can be selected by each axis independently without any limitation according to axis numbers.

One CP-9200SH can accommodate PO-01 modules up to 16 pieces. Therefore, it can control each axis independently up to 64 axes. Note that, to use other motion modules (such as the SVA module), the total maximum number is 16 modules.

The main features of the PO-01 module are shown in Table 2.1 and the basic specifications in Tables 2.2 and 2.3.

Table 2.1 Main Features of PO-01 Module

Item	Feature
Motion function	Positioning up to 4 axes, zero point return, interpolation, constant speed feed, and constant step feed Command : Pulse output Command unit : Pulse, mm, deg, and inch are available Emergency stop function : 1 point/1 axis
Pulse output scheme	Sign scheme, CW/CCW scheme

Tables 2.2 Basic Specifications of PO-01 Hardware

Item	Specifications
Command (Pulse train) Forward revolution command (CCW) Reverse revolution command (CW)	Pulse train command <ul style="list-style-type: none"> • Speed command : Sign + pulse, \pm pulse • Interface : 5 V differential type • Maximum frequency: 500 kpps
Digital input (DI: 5 points)	<ul style="list-style-type: none"> • Magnetization timing monitor/origin : 1 point • Emergency stop / decelerating to stop : 1 point (To latch the signal trailing) • Locking dog signal : 1 point(← available as general-purpose DI) • Limit 1 : 1 point(← available as general-purpose DI) • Limit 2 : 1 point(← available as general-purpose DI)
Digital output (DO: 4 points)	<ul style="list-style-type: none"> • Magnetization ON : 1 point • For general-purposes: 3 points

Tables 2.3 Basic Specifications of PO-01 Software

Item	Specifications	
On-board I/O		
DI	Five points *1 · Magnetization timing monitor / zero point · Limit switch · Reverse limit signal for zero point return · Forward limit signal for zero point return · Emergency stop / decelerated stop	
DO	Four points *2 · Magnetization ON · Electromagnetic brake release · For other general-purpose DO×2 points	
Motion control function		
The number of control axes	Up to 64 axes (4 axes / one module, up to 16 modules)	
Motion parameter	Fixed parameter	Setting at a CP-717 screen
	Set parameter	OWxx00 to OWxx3F (64 words / axis)
	Monitor parameter	IWxx00 to IWxx3F (64 words / axis)
Motion function	POSING	Positioning
	ZRET	Zero point return
	INTERPOLATE	Interpolation
	FEED	Constant speed feed
	STEP	Constant step feed
Command unit	pulse	Available
	mm	Available
	deg	Available
	inch	Available
Added function	Infinite-length axis selection	Available
	Over ride function	Available
	Soft limit function	Available
	Types of acceleration/deceleration	Linear acceleration/deceleration (Biased one is also available.)
		Exponential acceleration/deceleration (Bias setting is available.)
Simplified S-curve acceleration/deceleration		
Connection driver	Pulse train output type (CW/CCW scheme and Sign (CCW) + pulse (CW) scheme)	

*1 : Those except for "Magnetization timing monitor/zero point" and "Emergency stop" are available as general-purpose DI.

*2 : Those except for "Magnetization ON" are available as general-purpose DO.

DESCRIPTION OF **3** FUNCTION AND EXAMPLES OF USER PROGRAMS

This chapter describes main functions and operating method of the module.

Furthermore, simplified examples of user programs are described. Refer to the examples to prepare your own user programs.

3.1 Setting of Basic Motion Parameters

Descriptions are provided for motion parameters necessary for motion function. Be sure to read through this section before operating the module.

3.1.1 Command Units

The command units to be input to the module follow the settings of the motion fixed parameters mentioned below. Commands have units of pulse, mm, deg, and inch. The units of commands are set by bits 0 to 3 of the motion fixed parameter No.17, "Motion controller function selection flag." The "Minimum command unit" available for commanding the module is set by the unit setting mentioned above or the motion fixed parameter No.18, "Number of decimal places."

Table 3.1 Minimum Command Unit (One command unit)

Number of decimal places	Unit	Motion fixed parameter No.17 "Bit 0 to 3 of the "Motion controller function selection flag"			
		Pulse (=0)	mm (=1)	deg(=2)	inch(=3)
0	1 pulse	1mm	1deg	1inch	
1	1 pulse	0.1mm	0.1deg	0.1inch	
2	1 pulse	0.01mm	0.01deg	0.01inch	
3	1 pulse	0.001mm	0.001deg	0.001inch	
4	1 pulse	0.0001mm	0.0001deg	0.0001inch	
5	1 pulse	0.00001mm	0.00001deg	0.00001inch	

* Designate the "Number of decimal places" by the motion fixed parameter No.18, "Number of decimal Places."

3.1.2 Electronic Gears

The mechanical movement unit is called the "Output unit" against the command unit to be input to the module.

The electronic gear is the function by which the unit for position or speed is converted from the command unit (mm, deg, or inch) to the output unit (mm, deg, or inch).

It is possible to make the "Command unit" = "Output unit" by using the function of the electronic gear for the mechanical structure where the load axis rotates n times when the motor axis rotates m times.

Set the functions of electronic gears by the motion fixed parameter shown in Table 3.2. The function of the electronic gear is invalid when the unit selection is set to the pulse.

Table 3.2 Parameters of Electronic Gears

Motion fixed parameter	Name/Description
Bit 4 of No.17 "Motion controller function selection flag"	Electronic gear validity selection (0: invalid / 1: valid) * Setting the unit selection to the pulse results in invalid. Set it to "invalid = 0."
No.19 "Amount of movement per machine 1 revolution"	Amount of movement per machine 1 revolution * Setting the electronic gear validity selection to invalid (=0) will make the parameter setting invalid.
No.21 "Gear ratio of the motor side"	Gear ratio of the motor side * Setting the electronic gear validity selection to invalid (=0) will make the parameter setting invalid.
No.22 "Gear ratio at the machine side"	Gear ratio at the machine side * Setting the electronic gear validity selection to invalid (=0) will make the parameter setting invalid.

The meanings and setting examples for the above parameters are shown below.

Table 3.3 Table of Parameters / Definitions of the Electronic Gear

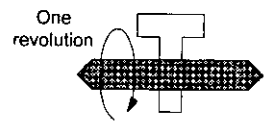
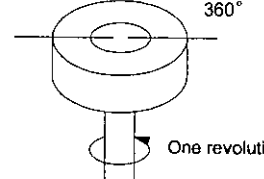
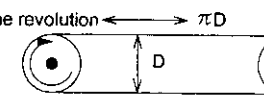
Motion fixed parameter No.	Name	Description	Initial value		
No.19	Amount of movement per one machine revolution	<ul style="list-style-type: none"> The parameter which represents the amount of movement of the load per one revolution of the load axis. Set the value obtained by dividing the amount of movement of the load by the command unit. $\text{No.19} = \frac{\text{The amount of movement of the load per one revolution of the load axis}}{\text{Command unit}}$ <ul style="list-style-type: none"> An example of the amount of movement of the load is shown below. 	10000		
		The amount of movement per one mechanical revolution		Loading example	
		P [mm]		Ball screw	 <p>One revolution</p> <p>P = pitch of the ball screw</p>
		360 [°]		Rotary table	 <p>360°</p> <p>One revolution</p>
		πD [mm]		Belt	 <p>One revolution $\longleftrightarrow \pi D$</p> <p>D</p>
		<ul style="list-style-type: none"> Setting range of No.19: 1 to 231-1[1=1 designated unit] A setting example <ul style="list-style-type: none"> The amount of load movement per one revolution of the load axis =12 mm Command unit = 0.001 mm In this case, $\text{No.19} = \frac{12\text{mm}}{0.001\text{mm}} = 12000 \text{ is set.}$ 			

(to be continued)

Table 3.3 Table of Parameters / Definitions of the Electronic Gear

(continued)

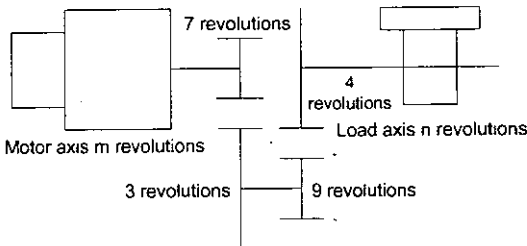
Motion fixed parameter No.	Name	Description	Initial value
No.21	Gear ratio of the motor side	<ul style="list-style-type: none"> The parameter which is used for setting the gear ratio between the motor and load. In the case where the load axis rotates n times when the motor axis rotates m times, set No.21 to m revolutions and No.22 to n revolutions. Setting range : 1 to 65535 [revolutions] ●Setting example  <p>In this case,</p> $\text{reduction ratio} = \frac{n}{m} = \frac{3}{7} \times \frac{4}{9} = \frac{4}{21}$ <p>Therefore, Set No.21 = 21 and No.22 = 4.</p>	1
No.22	Gear ratio of the machine side		

● A setting example of a parameter of the electronic gear (A) ... For ball screws

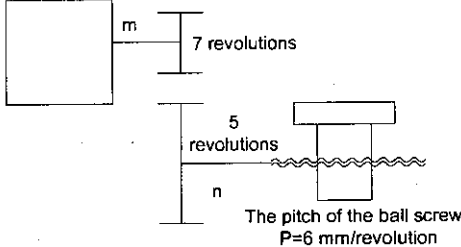

The pitch of the ball screw
P=6 mm/revolution

In order to make "Command unit" = "Output unit" = 0.001 mm in the above functional system, the setting of each parameter is as shown below.

- No.19 = $\frac{6\text{mm}}{0.001\text{mm}} = \boxed{6000}$
- Reduction ratio = $\frac{n}{m} = \frac{5}{7}$
- No.21 = $\boxed{7}$
- No.22 = $\boxed{5}$

● A setting example of a parameter of the electronic gear (B) ··· For revolving load motor

In order to make "Input unit" = "Output unit" = 0.1° in the above functional system, the setting of each parameter is as shown below.

- No.19 = $\frac{360^\circ}{0.1^\circ} = \boxed{3600}$
- Reduction ratio = $\frac{n}{m} = \frac{1}{30} = \frac{1}{3}$
- No.21 = $\boxed{3}$
- No.22 = $\boxed{1}$

3.1.3 Axis Selection

Position control is divided into two types; the finite distance position control by which movement such as the reciprocal motion is controlled within a specified range, that is, an interval between specified positions and the infinite distance position control by which movement is controlled only in one revolving direction. Furthermore, the infinite distance position control is divided into two types; one controls revolution to reset the belt conveyor to "0" after one revolution and the other controls revolution only in one direction without resetting it. For axis selection, select which position control method to use. Set Bit 5 of the motion fixed parameter No.17, "Motion controller function selection flag", for axis selection.

Table 3.4 Setting of Axis Selection

Types of position control	Setting of axis selection
Finite distance position control	Finite-length axis (=0)
Infinite distance position control by which revolution is directed in a single direction without a reset after one revolution.	Finite-length axis (=0)
Infinite distance position control by which revolution is reset after one revolution. (Set the reset position by the motion fixed parameter No.23, "Infinite long-axis reset position.")	Infinite-length axis (=1)

3.1.4 Position Commands

(1) Position Commands

There are two types of designations for setting the position command; the direct designation for setting the position command directly to OLxx12 and the indirect designation for setting the No. of position buffer which accommodates the position command to OLxx12. Furthermore, there are two methods for the direct designation; the absolute command method for setting an absolute position to OLxx12, and the increment addition method for setting the total amount of the current movement added by the value of the previous position command (the previous value of OLxx12) to OLxx12.

In the case of the indirect designation which designates the No. of a position buffer, the position stored in the position buffer is regarded as an absolute position.

Parameters related to the position command are shown in Table 3.5.

Table 3.5 Position Command Parameters

Types of Parameter	Parameter No. (Register No.)	Name	Description	Initial Value
Motion Set Parameter	Bit 12 of OWxx01	Position command value selection	Set the designation method of the position command. 0: The direct designation Set the position data directly to OLxx12. Use bit 14 of OWxx01 to designate either the absolute position method or the increment addition method for position data. 1: The indirect designation Set the No. of the position buffer to OLxx12. An absolute position is required to be stored in the designated position buffer in advance.	0
Motion Set Parameter	Bit 14 of OWxx01	Position command type	Designate the type of position data. 0: Absolute position method Set an absolute position to OLxx12. 1: Increment addition method Set the amount of current movement added by the previous value of OLxx12 to OLxx12. (Note) This is invalid when the position command value selection is the position buffer (the indirect designation).	0
Motion Set Parameter	OLxx12	Position command setting	Set the position data. (Note) Setting data differs according to the position command value selection (bit 12 of OWxx01) and the position command type (bit 14 of OWxx01).	0

Table 3.6 Position Command Value Selection

Position Command Value Selection (bit 12 of OWxx01)	Position Command Type (bit 14 of OWxx01)	Position Command (OLxx12)
0 (Direct designation)	0 (Absolute position method)	Set an absolute position. (Example) OLxx12 ← 10000 OLxx12 ← 20000
	1 (Increment addition method)	Set the amount of current movement (the incremental amount) added by the previous value of OLxx12 to OLxx12. OLxx12 ← previous OLxx12 + the incremental amount of movement (Example) When the previous OLxx12 = 1000 and current amount of movement = 500, OLxx12 ← 1000 + 500 = 1500.
1 (Indirect designation)	0	Set the No. of the position buffer. An absolute position is required to be stored in the position buffer with the designated No. in advance.

In case of the position command for the infinite-length axis, set the increment addition method (Bit 14 of OWxx01 = 1). That is, set a new position command (OLxx12) at a value obtained by adding the current amount of movement (incremental amount of movement) to the previous position command (OLxx12).

Note that the position command (OLxx12) is not set to the range from 0 to (the reset position of infinite-length axis -1).

What is the position buffer?

A position data group for every axis can be stored in the buffer (the position buffer) of the PO-01 module. Designating the "Buffer No." as position data (OLxx12) will lead to the same operation as by the setting of absolute position in a program.

The position buffer accommodates up to 256 points \times 4 axes.

Note

The position buffer is erased by turning the power off or the master reset of the CPU module. For this reason, make sure to set the buffer at the time of power start-up or before using the position buffer.

■ Preparing the position buffer

Prepare the position buffer in advance using the motion parameters shown in Table 3.7.

Table 3.7 Parameters for Preparing the Position Buffer

Name	Register No.	Setting Range	Description
Position buffer access No.	OLxx38	1 to 256	Setting of Position buffer No.
Position buffer writing data	OLxx3A	-2^{31} to $2^{31}-1$	Setting of data to be written to the position buffer
Motion command control flag (MCMDCtrl)	OBxx21E (Bit 14 of OWxx21)	0/1	Execution of writing data to the position buffer 0: Not execute, 1: Execute writing

■ Reading position buffer data

The motion set parameters in Table 3.8 allow data in the position buffer to be read out to set to motion parameters. This is used for checking data, etc. Note that it takes two scans (H scan) to issue the read-out command and then set data to the motion monitor parameter (ILxx28).

Table 3.8 Parameters for Preparing the Position Buffer Data

Name	Register No.	Setting Range	Description
Position buffer access No.	OLxx38	1 to 256	Setting of Position buffer No.
Motion command control flag (MCMDCtrl)	OBxx21F (Bit 15 of OWxx21)	0/1	Execution of read-out from the position buffer 0: Not execute 1: Execute read-out
Read-out data from the position buffer	ILxx28	-2^{31} to $2^{31}-1$	Data read out from the position buffer

■ Using the position buffer as position command

Data in the position buffer can be used as position command values in accordance with the motion parameter in Table 3.9.

Table 3.9. Motion Parameters

Name	Register No.	Setting Range	Description
Position command setting (XREF)	OLxx12	1 to 256	Set the position buffer No. instead of the position command value.
Run command setting (SVRUNCMD)	OBxx01C (Bit 12 of OWxx01)	1	Select to use the position buffer 0: Data of XREF(OLxx12) is the position command value 1: Data of XREF(OLxx12) is the position buffer No.

Information

Two patterns of positioning when the position command is changed in position control mode are explained.

The positioning is performed in either of the following two patterns depending on the current position, target position, and deceleration start position when the position command is changed in position control mode (Target Position Change Point).

The deceleration start position is the position where the deceleration starts so that the positioning to the target position completes at the set deceleration time.

- (a) Current position < Target position and Current position ≤ Deceleration start position
The axis decelerates at the set deceleration time.

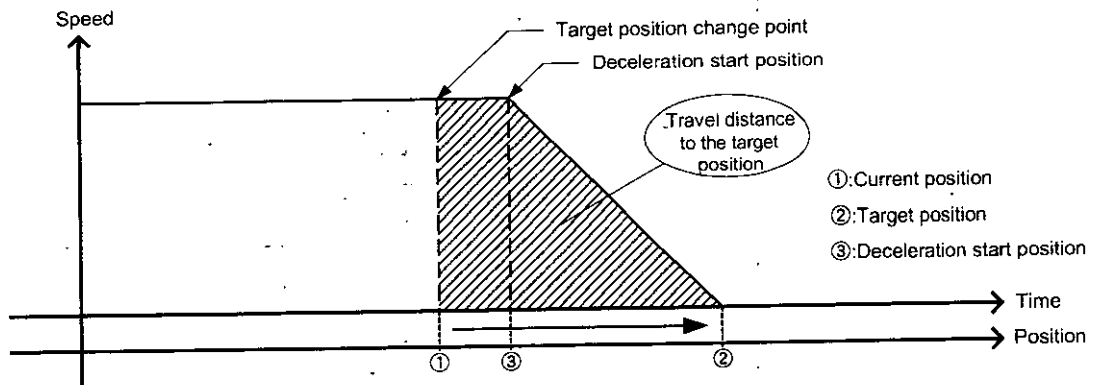

- (b) Current position < Target position and Current position > Deceleration start position or Current position ≥ Target position
The axis decelerates to a stop at the set deceleration time, and then moves in the reverse direction to complete the positioning to the target position at the set acceleration/deceleration time.

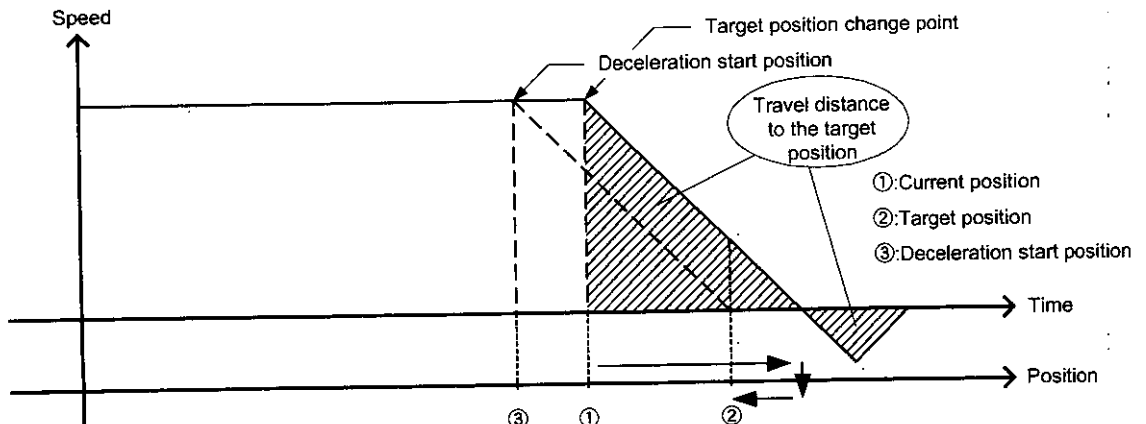

As the axis has passed over point ③ to start deceleration, it decelerates to a stop from the target position change point, and starts positioning to the target position from the position where the axis stopped.

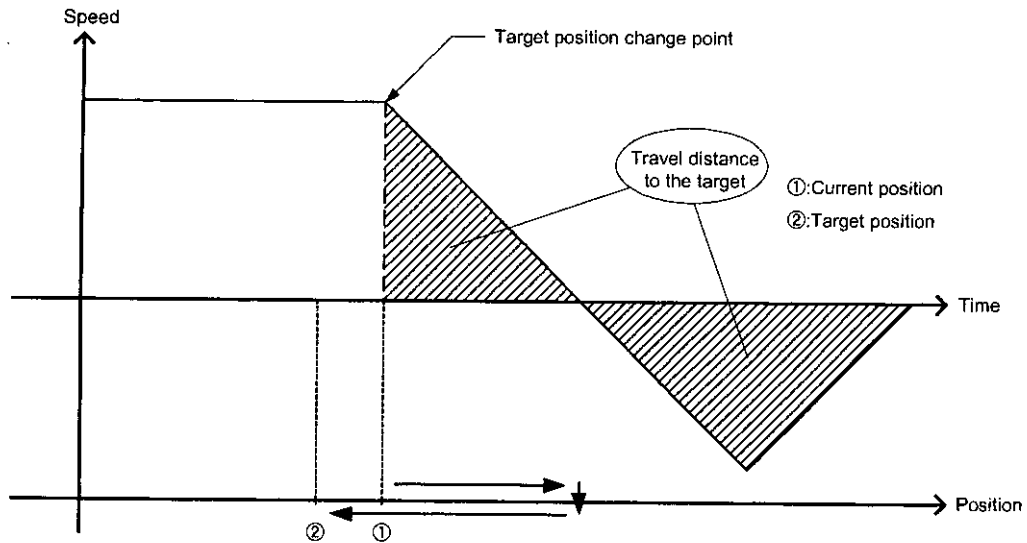

As the target position is before the current position, the axis decelerates to a stop, and starts positioning to the target position from the position where the axis stopped.

(2) Position Monitoring

Position monitoring adopts the parameters shown in Table 3.10.

Table 3.10. Position Monitoring Parameters

Motion monitor parameter No. (register No.)	Name	Description
ILxx02	A calculated position of the machine coordinate system (CPOS)	A calculated position of the machine coordinate system which is controlled by the PO-01 module is reported. Position data reported to this parameter is normally the target position for every scan. (Note) Setting the axis selection to the infinite-length axis will the range from "0" to "the reset position of the infinite-length axis - 1" to be reported. For the position command in the case of the infinite-length axis, add the current amount of movement (the incremental amount of movement) to the previous position command (OLxx12) to set a new position command (OLxx12). Note that the position command (OLxx12) is not set within the range from "0" to "the reset position of the infinite-length axis - 1."
ILxx18	A command position of the machine coordinate system (MPOS)	The position which the PO-01 module generates as output of pulse trains toward outside of it and the command position of the machine coordinate system are reported. Under the status of machine lock, these data are not updated. (The pulse trains are not sent toward outside of the module under the status of machine lock.) The position is the same as that of the calculated position (CPOS) of the machine coordinate system when the machine lock function is not used.
ILxx2E	A calculated position of the command coordinate system (POS)	When the axis selection is the infinite-length axis, this parameter will work. When the infinite-length axis is selected, the target position is reported to this parameter for every scan corresponding to the position command. (Note) For the finite-length axis, this is the same as that of the calculated position (CPOS) of the machine coordinate system.

■ What is the machine coordinate system?

This is the basic coordinate system which can be set by executing of "Zero point return (ZRET)" or operating "Zero point setting (ZSET)."

The PO-01 module controls positions by means of this machine coordinate system.

3.1.5 Speed Commands

To set speed commands such as rapid feed speed, approach speed, and creep speed, two methods are available; one is to set in the unit of command and the other is to set by the proportion (%) against the rated revolving speed. Parameters relating to speed command are shown in Table 3.11.

Table 3.11. Speed Command Parameters

Type of parameter	Parameter No. (Register No.)	Name	Description
Motion fixed parameter	No.7	Rated revolution setting	Set the number of revolution for the revolution of the motor at the rated value (100% speed).
	No.33	The number of pulses per one revolution of the motor	Set the number of pulses per one revolution of the stepping motor.
Motion set parameter	Bit 13 of OWxx01	Speed command value selection	Designate the setting units of the rapid feed speed, approach speed, and creep speed, and the register No. of the rapid feed speed. 0: Use OLxx22 (unit: 10 ⁿ command unit/min) as the rapid feed speed. The units for the approach speed (OWxx0A) and the creep speed (OWxx0B) are 1 = 10 ⁿ command unit/min. 1: Use OWxx15 (unit = the proportion corresponding to the rated revolution speed (1=0.01%)) as the rapid feed speed. The units for the approach speed (OWxx0A) and the creep speed are the proportion corresponding to the rated revolution speed (1=0.01%).
	OWxx0A	Approach speed setting	Units are different according to the setting of the speed command value selection (Bit 13 of OWxx01). (1) For the speed command value selection = 0, set in the command unit. 1=10 ⁿ command unit / min (n: number of decimal places) In units of pulses :1=100 pulses/min In units of mm :1=1mm/min In units of deg :1=1deg/min In units of inches :1=1inch/min (2) For the speed command value selection = 1, set in proportion (%) corresponding to the rated revolution speed. 1=0.01%
	OWxx0B	creep speed setting	
	OWxx15	Speed command setting	Valid when the setting of the speed command value selection (Bit 13 of OWxx01) is set to "1." Set the proportion (1=0.01%) corresponding to the rated revolution speed as the rapid feed speed. (Note) Invalid when the speed command value selection = 0.

(to be continued)

Table 3.11. Speed Command Parameters

(continued)

Type of parameter	Parameter No. (Register No.)	Name	Description
Motion set parameter	OLxx22	Rapid feed speed	Valid when the speed command value selection (Bit 13 of OWxx01) is set to "0." Set in the command unit as the rapid feed speed. $1=10^n$ command unit/min (n: number of decimal places) Unit selection will result in the following. In units of pulses :1=100 pulses/min In units of mm :1=1mm/min In units of deg :1=1deg/min In units of inches :1=1inch/min
	OWxx2C	Override	The settings of the rapid feed speed can be "changed to use." (Note) "OVERRIDE" means "make invalid" in English, however, take it as "to change to use" settings. Available for switching the override either to "valid" or "invalid" is Bit 9, "Override validity selection" of the motion fixed parameter No.17, "Motion controller Function Selection Flag." Setting it to "invalid" will result in 100 % speed of the setting of the rapid feed speed.

Setting examples for the parameters mentioned above are shown in Table 3.12.

Table 3.12. Setting Examples of Parameters

Types of Parameter	Parameter No. (Register No.)	Name	Description	Initial Value
Motion fixed parameter	No.7	Number of rated revolution setting	To revolve the pulse motor, which revolves 0.18° by one pulse, at the rated speed (100%) with 6 kpps, $\text{No.33} = \frac{360^\circ}{0.18^\circ} = 2000(\text{ppr})$ $\text{No.7} = 6000(\text{pps}) \div \frac{360^\circ}{0.18^\circ} \times 60(\text{s})$ $= 180(\text{rpm})$	100
	No.33	The number of pulses per one revolution of the motor		200
Motion set parameter	Bit 13 of OWxx01	Speed command value selection	<p>(1) When the speed command value selection is set to "0":</p> <p>① when pulse is selected as the unit; in the setting of the fixed parameter mentioned above (at rated revolution speed, 180rpm), for operation at rapid feed speed, 90 rpm, approach speed, 18 rpm, and creep speed, 19 rpm; $\text{OWxx0A} = 18(\text{rpm}) \times 2000(\text{ppr}) \div 100 = 360$ $\text{OWxx0B} = 9(\text{rpm}) \times 2000(\text{ppr}) \div 100 = 180$ OWxx15=----(Invalid) $\text{OLxx22} = 90(\text{rpm}) \times 2000(\text{ppr}) \div 100 = 1800$ $\text{OWxx2C} = 10000(100\%)$</p> <p>② when mm is selected as the unit; in the setting of the fixed parameter mentioned above (at rated revolution speed, 180rpm), for operation of the mechanical structure where the amount of movement is 10 mm by one revolution at rapid feed speed, 900 mm/min, approach speed, 180 mm/min, and creep speed, 90 mm/min; $\text{OWxx0A} = 180$ $\text{OWxx0B} = 90$ OWxx15=----(Invalid) $\text{OLxx22} = 900$ $\text{OWxx2C} = 10000(100\%)$</p> <p>(2) When the speed command value selection is set to "1": in the setting of the fixed parameter mentioned above (at rated revolution speed, 180rpm), for operation at rapid feed speed, 90 rpm, approach speed, 18 rpm, and creep speed, 9 rpm; $\text{OWxx0A} = \frac{18(\text{rpm})}{180(\text{rpm})} \times 10000 = 1000(10.00\%)$ $\text{OWxx0B} = \frac{9(\text{rpm})}{180(\text{rpm})} \times 10000 = 500(5.00\%)$ $\text{OWxx15} = \frac{90(\text{rpm})}{180(\text{rpm})} \times 10000 = 5000(50.00\%)$ OLxx22=----(Invalid) $\text{OWxx2C} = 10000(100\%)$</p> <p>(3) When the operating speed is halved with the rapid feed speed, approach speed, and creep speed remained as they were; $(\text{OWxx2C}) = 5000(50.00\%)$</p> <p>(Note) Set Bit 9, "Override validity selection" of the motion fixed parameter No.17 to "valid"(=1).</p>	0
	OWxx0A	Approach speed		0
	OWxx0B	Creep speed		0
	OWxx15	Speed command setting		0
	OLxx22	Rapid feed speed		0
	OWxx2C	Override		100%

3.2 Positioning (POSING)

Positioning is performed at the commanded position by the designated acceleration/deceleration time-constant and at the designated rapid feed speed. The rapid feed speed and the position command value can be changed even during operation. When a changed position command value does not allow a distance for deceleration or requires movement in the reverse direction, movement is decelerated to stop once and then positioning is carried out at the position command value.

A block diagram is shown in Fig.3.3. Positioning for every axis is performed as follows. The register No. corresponds to the first axis of the module No.1. When the module No. or the axis No. is different, refer to Section 1.3, "Module No. and Motion Parameter Register No." to substitute the register No. For the motion parameter to be used for positioning, a circle "○" is displayed at the "Positioning" column of the "Motion command code to validate data" in Section 5.1.2, "List of Motion Set Parameters" and in Section 5.1.3, "List of Motion Monitor Parameters."

- ① Set the initial value of the motion fixed parameter and motion set parameter. Set them so as to meet the requirements of the user's machines by means of the Parameter Setting Window of CP-717.
- ② Select the position control mode (PCON) (Bit 2 of OWC000).
* It is recommended to set the initial value at the Parameter Setting Window of CP-717.
- ③ Set the position command setting (OLC012) and rapid feed speed (OLC022 or OWC015). If necessary, set such motion set parameters to be used for positioning (POSING) as the linear acceleration/deceleration time-constant (OWC00C, OWC00D), and the filter time-constant(OWC014).
- ④ Turn on the Magnetization ON (RUN) (Bit 0 of OWC001).
- ⑤ Set the positioning (POSING = 1) to the motion command code (OWC020).
- ⑥ Setting the positioning (POSING) to the motion command code, the axis will perform positioning operation by the designated motion parameter. The settings of the motion parameter can be changed even during the positioning operation. When the suspension has been completed, HOLDL(Bit 1 of IWC015) is turned "ON." To suspend positioning, turn HOLD (Bit 0 of OWC021) "ON." To release the suspension, turn the HOLD (Bit 0 of OWC021) "OFF". To abort positioning, turn ABORT (Bit 1 of OWC021) "ON." During abortion, BUSY (Bit 0 of IWC015) is kept "ON", whereas it turns "OFF" when the abortion has been completed.
(Note) After abortion has been completed, releasing the abortion (turn ABORT "OFF") will result in as follow.
 - If the position command type (Bit 14 of OWC001) follows the absolute position method (=0), positioning is re-started against the position command (OLC012).
 - In the case of the incremental value adding method (=1), positioning is suspended until a new position command (OLC012) is set.
- ⑦ Completing the issue (Bit 2 of IWC015 is turned "ON") will cause the positioning completion signal POSCOMP (Bit D of IWC000) is turned "ON."

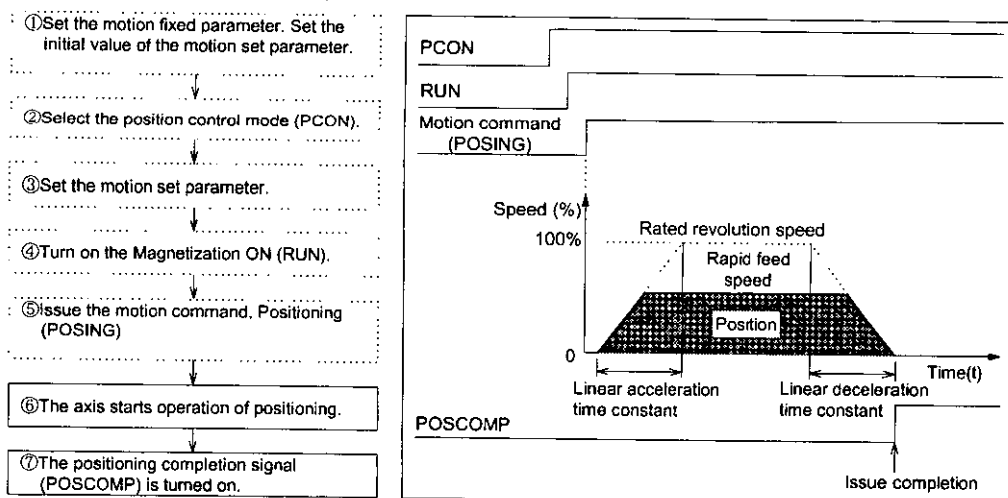

□ shows the system in the operating mode.
 □ shows that the user is required to set.

■ An example of user's programs (Point-to-point positioning)

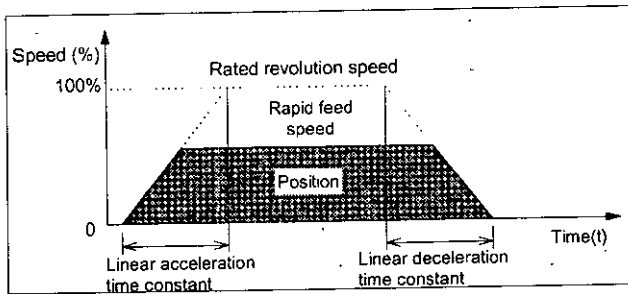

Fig.3.1 An example of positioning pattern

<Preconditions>

Assume that initial values for the motion fixed parameter and motion set parameter are the same as in Section 5.3, "Examples of Motion Parameter Setting."

<Operation Conditions>

Movement follows the pattern shown in Fig.3.1 and then stops at an absolute position of 10000 pulses.
Position command : OLC012 = 10000 pulses.

This example uses the first axis of module No.1.

When the module No. or the axis No. is different, refer to Section 1.3, "Module No. and Motion Parameter Register No." to substitute the register No.

Refer to Chapter 5, "Motion Parameters" for the details of the register (OWxxxx) in use.

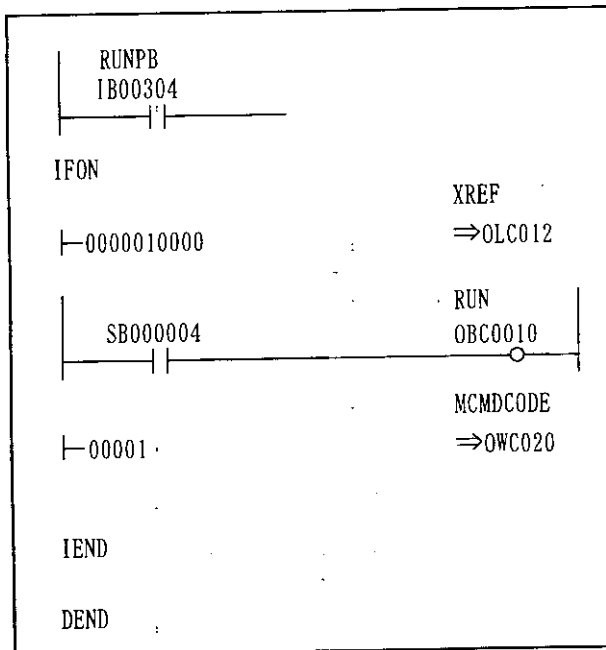

Position command pulse (XREF)
(Absolute value :10000)

Positioning (POSING) is issued as the run command (RUN), a motion command to the driver.

Turning IB00304 ON will allow the position control to start to reach an absolute position 10000.

Having reached the absolute position 10000 will cause the position completion signal IBC000D to be turned ON.

Fig. 3.2 An example of positioning program (DWG H03)

The example in Fig.3.2 has been simplified, however, each register can be controlled by the user's program as intended.

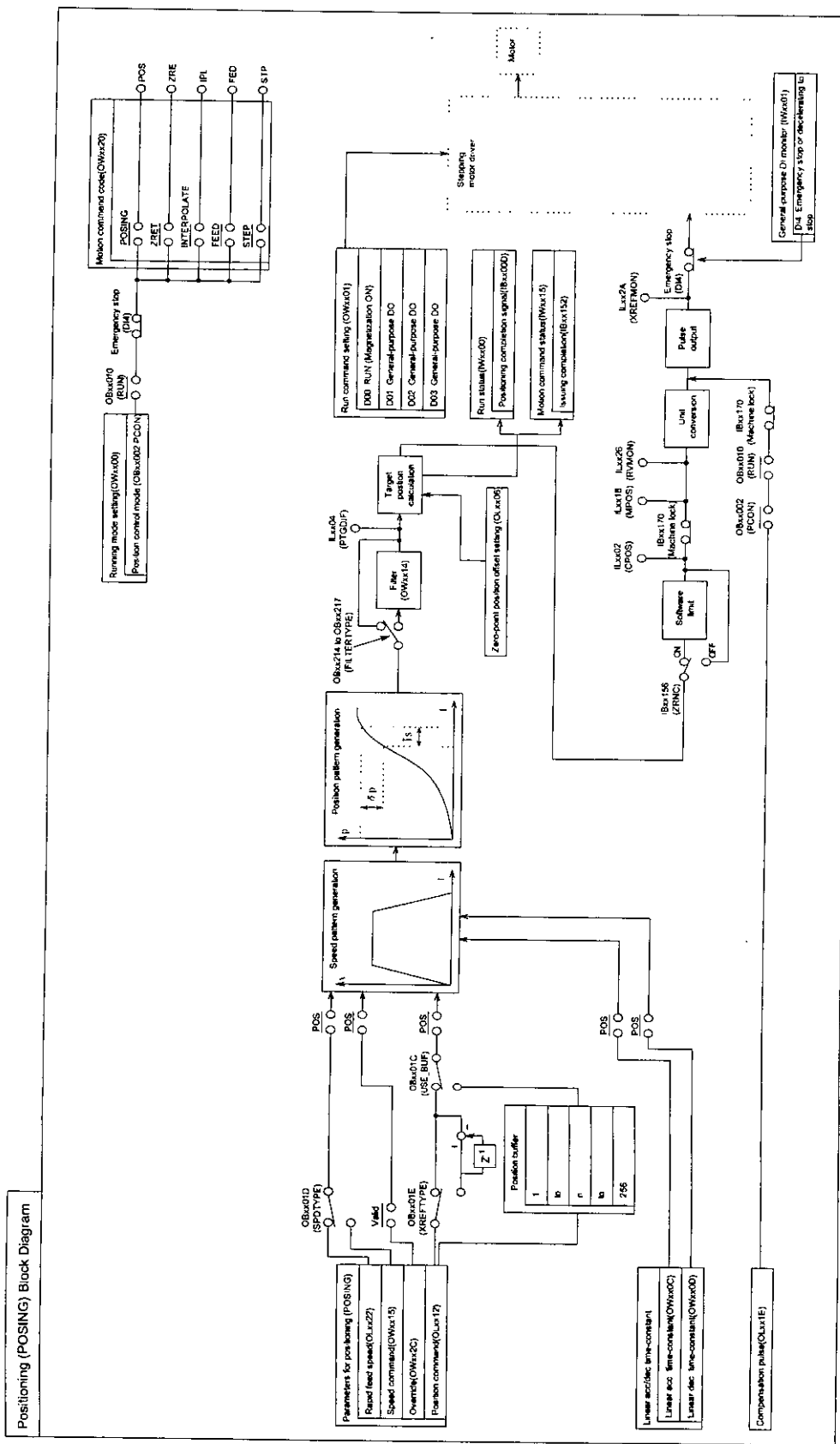

Fig. 3.3 Positioning (POSING) Block Diagram

3.3 Zero Point Return (ZRET)

"Zero point return" is the movement of returning to the machine coordinate zero point. Power failure will cause position data of the machine coordinate system to vanish and therefore a new machine coordinate zero point must be determined when power is turned on. The zero point is determined generally by using the limit switch which shows the zero point pulse and zero point area.

Fig.3.4 shows a block diagram.

There are three methods for zero point return:

- ① DEC1 + ZERO signal
(Limit switch (with width)) + (Zero point signal)
- ② DEC2 + ZERO signal
(Limit switch (without width)) + (Zero point signal)
- ③ DEC1 + LMT + ZERO signal
(Limit switch (with width)) + (Limit signal for zero point return) + (Zero point signal)

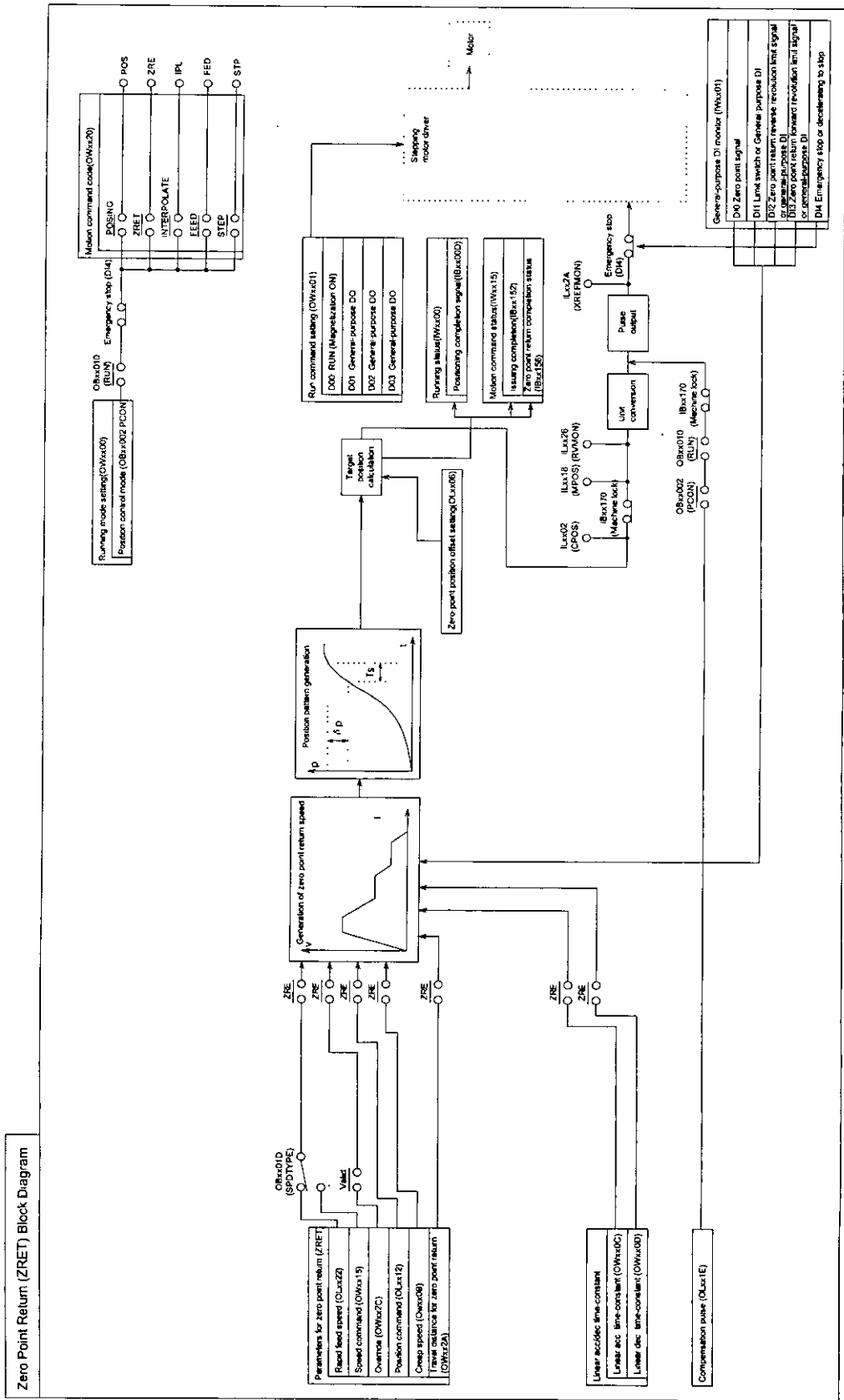
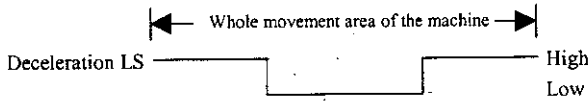

Fig. 3.4 Zero point return (ZRET) Block Diagram

3.3.1 DEC1 + ZERO Signal Method

Zero point return is accomplished by using the limit switch (deceleration LS/DI input) and the zero point signal (DI input) from the rapid feed by linear acceleration/deceleration.

This is used when the limit switch has the following mechanical configuration.



The axis:

- ① Moves at rapid speed in the direction designated by the motion set parameter (OBxx009).
- ② Decelerates down to the approach speed at the trailing of the dog (deceleration LS) signal.
- ③ Decelerates down to the creep speed at the rise of the dog (deceleration LS) signal.
- ④ Moves by the final travel distance for zero point return (OLxx2A) from the first zero point signal (DI input) after the dog is turned HIGH and then stops at a point which is taken as the machine coordinate zero point.

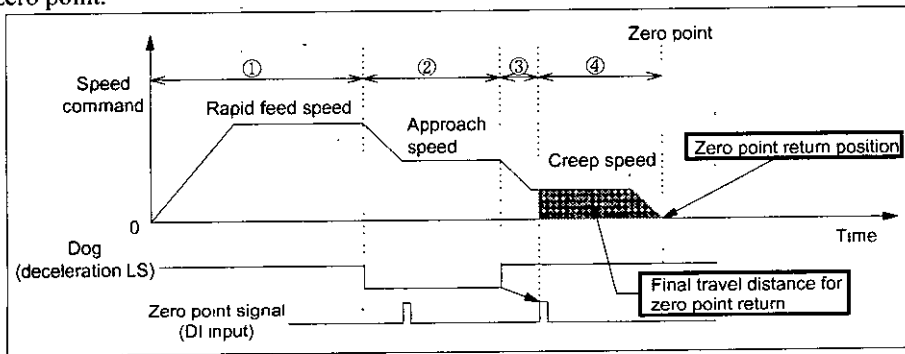

3.3.2 DEC2 + ZERO Signal Method

Zero point return is accomplished by using the limit switch (deceleration LS/DI input) and the zero point signal (DI input) from the rapid feed by linear acceleration/deceleration.

This is used when the limit switch has the following mechanical configuration.

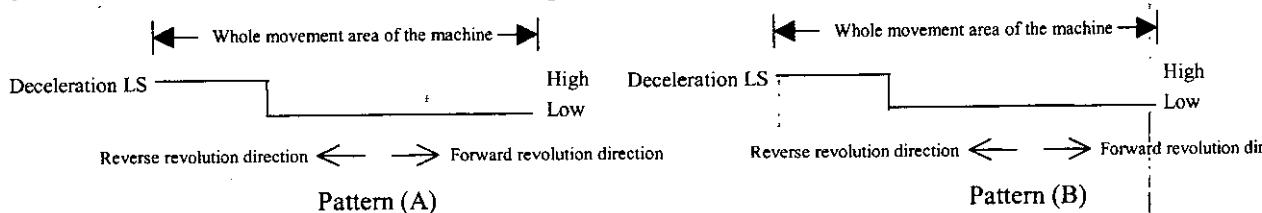

- * For pattern (B), turn ON the deceleration LS reverse revolution selection (Bit 10) of the motion fixed parameter No.17.

■ Operation on starting the zero point return with the dog (deceleration LS) signal at High area

The axis:

- ① Moves at rapid speed in the forward direction.
- ② Decelerates at the trailing of the dog (deceleration LS) signal.
- ③ Moves at the approach speed in the reverse direction.
- ④ Decelerates at the rise of the dog (deceleration LS) signal.
- ⑤ Moves at the creep speed in the forward direction.
- ⑥ Moves by the final travel distance for zero point return (OLxx2A) from the first zero point signal after the trailing of the dog (deceleration LS) signal has been detected and then stops at a point which is taken as the machine coordinate zero point.

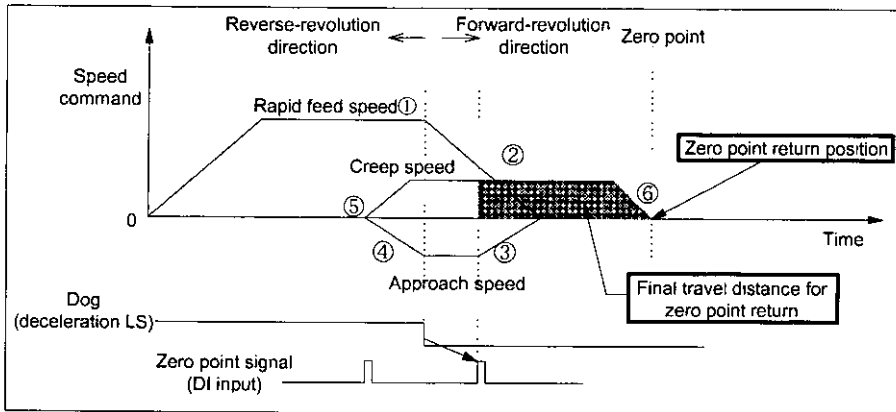

■ Operation on starting the zero point return with the dog (deceleration LS) signal at Low area

The axis:

- ① Moves at the approach speed in the reverse direction.
- ② Decelerates at the rise of the dog (deceleration LS) signal.
- ③ Moves at the creep speed in the forward direction.
- ④ Moves by the final travel distance for zero point return (OLxx2A) from the first zero point signal after the trailing of the dog (deceleration LS) signal has been detected and then stops at a point which is taken as the machine coordinate zero point.

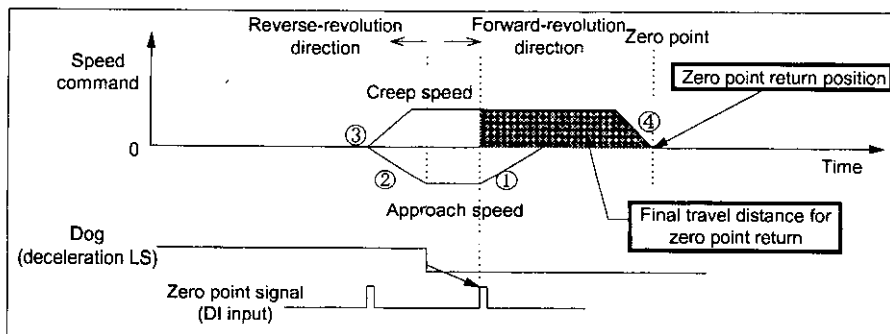

3.3.3 DEC1 + LMT + ZERO Signal Method

Zero point return is accomplished by using the limit switch (deceleration LS : DI input), the limit signal for zero point return (DI input), and the zero point signal (DI input) from the rapid feed by linear acceleration/deceleration.

This is used when the limit switch (deceleration LS) and the limit signal for zero point return have the following mechanical configuration.

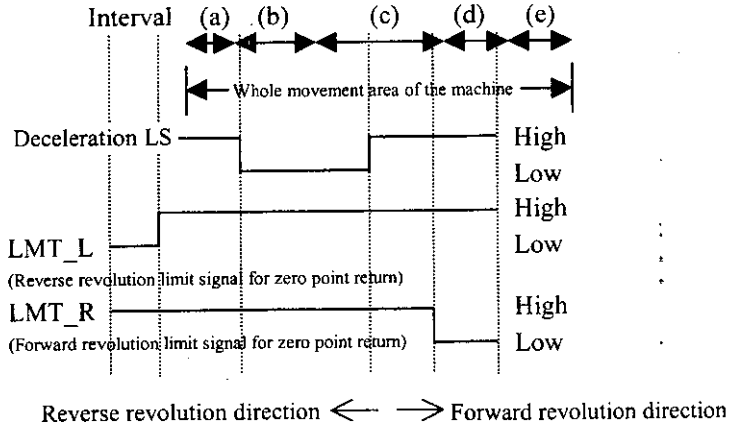

■ Operation on starting the zero point return within interval (a)

The axis:

- ① Moves at the rapid speed in the forward direction.
- ② Decelerates at the trailing of the dog (deceleration LS) signal.
- ③ Moves at the approach speed in the reverse direction.
- ④ Decelerates at the rise of the dog (deceleration LS) signal.
- ⑤ Moves at the creep speed in the forward direction.
- ⑥ Moves by the final travel distance for zero point return (OLxx2A) from the first zero point signal after the trailing of the dog (deceleration LS) signal has been detected and then stops at a point which is taken as the zero point of the machine coordinate system.

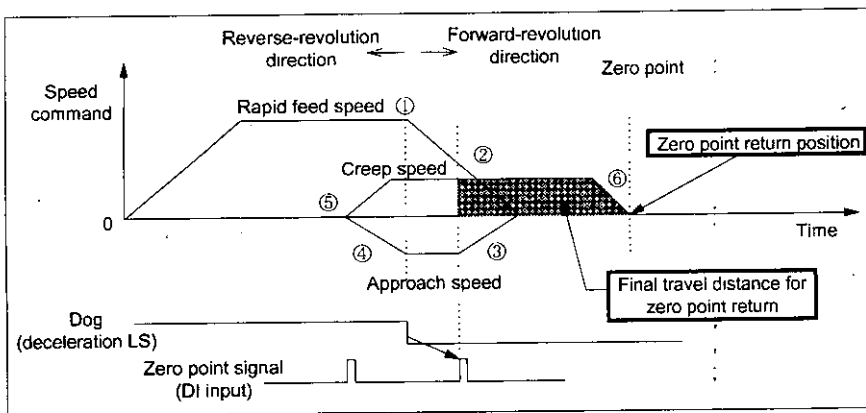

■ Operation on starting the zero point return within interval (b)

The axis:

- ① Moves at the approach speed in the reverse direction.
- ② Decelerates at the trailing of the reverse revolution limit signal for zero point return (LMT_L).
- ③ Moves at the rapid speed in the forward direction.
- ④ Decelerates at the trailing of the dog (deceleration LS) signal.
- ⑤ Moves at the approach speed in the reverse direction.
- ⑥ Decelerates at the rise of the dog (deceleration LS) signal.
- ⑦ Moves at the creep speed in the forward direction.
- ⑧ Moves by the final travel distance for zero point return (OLxx2A) from the first zero point signal after the trailing of the dog (deceleration LS) signal has been detected and then stops at a point which is taken as the machine coordinate zero point.

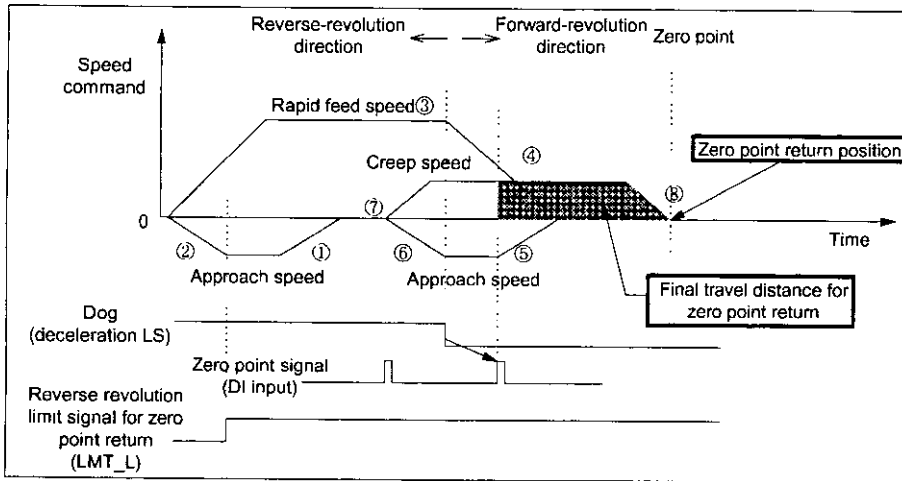

■ Operation on starting the zero point return within interval (c)

The axis:

- ① Moves at the creep speed in the reverse direction.
- ② Decelerates at the rise of the dog (deceleration LS) signal.
- ③ Moves at the creep speed in the forward direction.
- ④ Moves by the final travel distance for zero point return (OLxx2A) from the first zero point signal after the trailing of the dog (deceleration LS) signal has been detected and then stops at a point which is taken as the machine coordinate zero point.

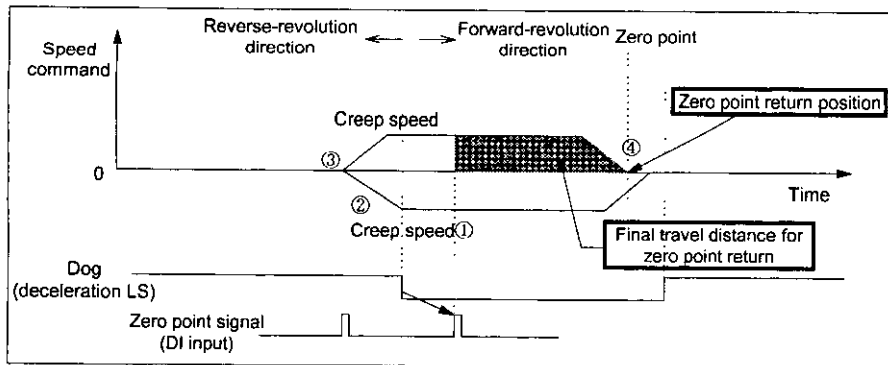

■ Operation on starting the zero point return within interval (d) and (e)

- ① Moves at the approach speed in the reverse direction.
- ② Decelerates at the rise of the dog (deceleration LS) signal.
- ③ Moves at the creep speed in the forward direction.
- ④ Moves by the travel distance for zero point return from the first zero point signal after the trailing of the dog (deceleration LS) signal has been detected and then stops at a point which is taken as the machine coordinate zero point.

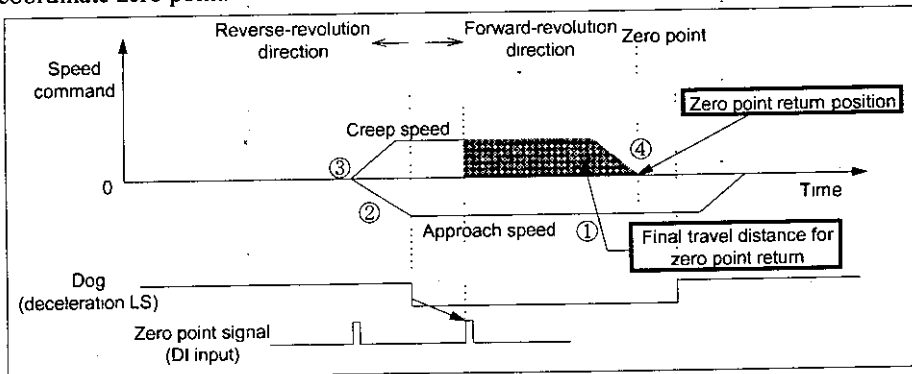

■ An example of the method for zero point return operation

Zero point return for each axis is performed as described below. Take "DECI + ZERO" signal method as an example the register No. corresponds to the first axis of module No.1. When the module No. or the axis No. is different, refer to Section 1.3, "Module No. and Motion Parameter Register No." to substitute the register No. For the motion parameter to be used for zero point return, a circle "○" is displayed at the "Zero point return" column of the "Motion command code to validate data" in Section 5.1.2, "List of Motion Set Parameters" and in Section 5.1.3, "List of Motion Monitor Parameters."

- ① Set the initial value of the motion fixed parameter and motion set parameter. Set them so as to meet the requirements of the user's machines by means of the Parameter Setting Window of CP-717.
- ② Select the position control mode (PCON) (Bit 2 of OWC000).
* It is recommended to set the initial value at the Parameter Setting Window of CP-717.
- ③ Set the approach speed (OWC00A), creep speed (OWC00B), and rapid speed (OLC022 or OWC015).
Set such motion set parameters to be used on zero point return (ZRET) as the linear acceleration/deceleration time constant (OWC00C, OWC00D) and the final travel distance for zero point return (OLC02A).
- ④ Turn the on the Magnetization ON (RUN) (Bit 0 of OWC001).
- ⑤ Set zero point return (ZRET = 3) to the motion command code (OWC020).
- ⑥ Setting zero point return (ZRET) to the motion command will cause the axis to move at the rapid speed in the direction designated by the zero point return direction selection (Bit 9 of OWC000).
The settings of the motion parameters cannot be changed during zero point return.
Furthermore, suspending the operation is not allowed during zero point return. To abort positioning, turn ABORT (Bit 1 of OWC021) on. The BUSY (Bit 0 of IWC015) is kept "ON" during the abortion and turned "OFF" on completing the abortion.
(Note) On completion of the abortion, releasing the abortion (turning ABORT "OFF") will result in keeping stopped.
- ⑦ The axis decelerates down to the approach speed at the trailing of the dog (deceleration LS) signal.
- ⑧ The axis decelerates down to the creep speed at the rise of the dog (deceleration LS) signal.
- ⑨ The axis moves by the final travel distance for zero point return (OLC02A) from the first zero point signal after the dog has been turned to HIGH and then stops at a point to take it as the machine coordinate zero point.
Setting the offset value of zero point is also allowed. (Setting the offset value of zero point to 100 makes the position data 100.) Set in advance the offset value of zero point by the motion set parameter (OLC006).
- ⑩ Completing the issue (Bit 2 of IWC015 is turned "ON") leads to the completion of the zero point return. Completion of the zero point return will cause the completion status of zero point return ZRNC (Bit 6 of IWC015) to turn "ON."
- ⑪ Check to see if the completion status of zero point return (ZRNC) has been turned "ON", and set NOP (=0) to the motion command code (OWC020).

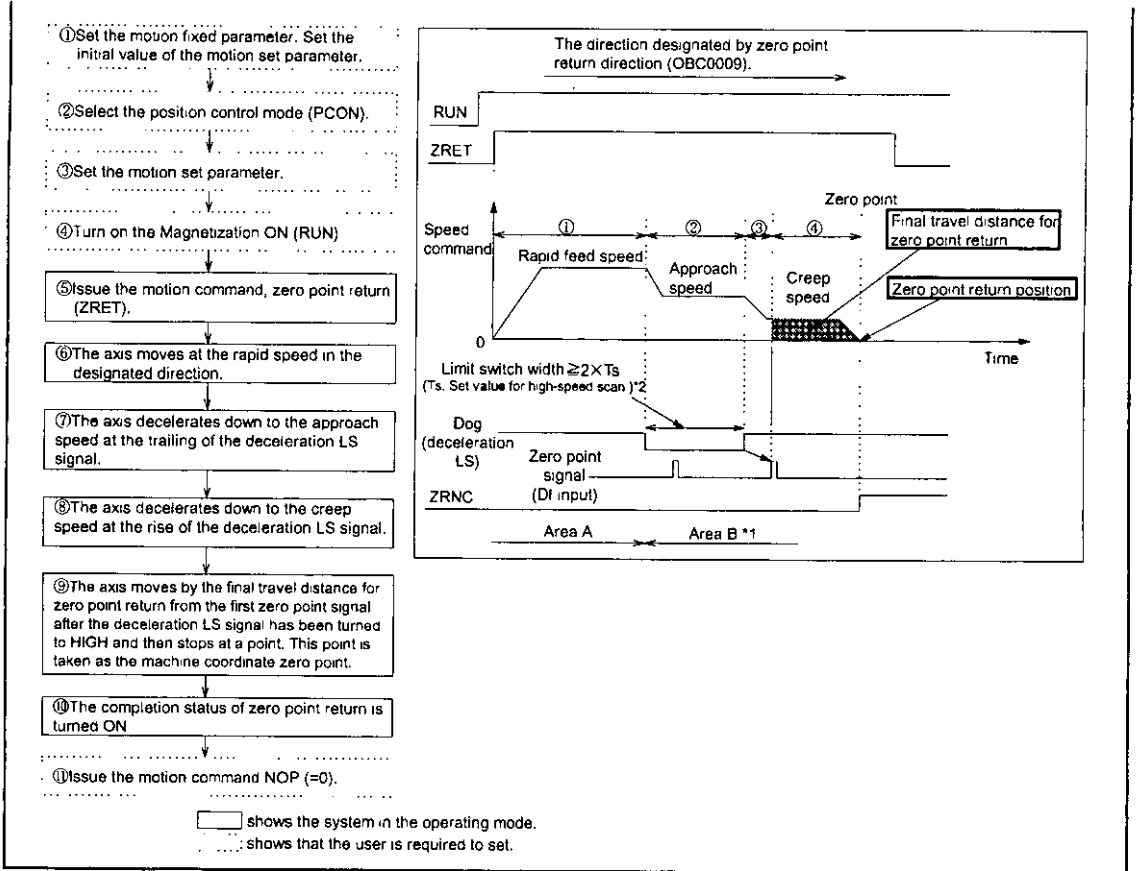

- *1 : The machine in area B after powered will not allow for proper zero point return. Return the machine positively to area A to carry out zero point return.
- *2 : The deceleration LS requires a setting value at least twice or more than the high-speed scan. The measure of the deceleration LS width can be calculated by the equations below.

$T_s(S) = \text{High-speed scan set value (ms)} / 1000$
 $f(m/s) = k \times \{NR \times MPPS\} / 60$
 k : Weight of one pulse (m/ pulse)
 NR : Rated revolution speed (r/min)
 MPPS : The number of pulses per one revolution of the motor
 f : 100% speed (m/s)
 $t(s) = \text{linear acceleration/deceleration time (s)}$
 Let $\alpha (m/s^2) = f/t$
 where α : Acceleration/deceleration time constant (m/s²).
 Then $L = 1/2 L = 1/2 \cdot \alpha (2 \times T_s)^2 = 2 \alpha T_s^2$
 gives the measure.

The measure of rapid speed can be calculated by the equations below.
 Let $V_a = \text{Rapid feed speed (\%)}$.
 Then, set as shown below.
 $v_a = f \times V_a / 100$
 $L \geq 1/2 \cdot \{v_a^2 / a\}$

*3 : When the distance set to the "Final travel distance for zero point return" is too short, the axis passes the zero point and then returns.

The measure of the final travel distance for zero point return can be calculated by the equations below.
 Let V_c = creep speed (%).
 Then $v_c = f \times V_c / 100$
 $x = 1/2 \cdot \{v_c^2 / a\}$
 gives the measure.

■ An example of user's programs (Zero point return)

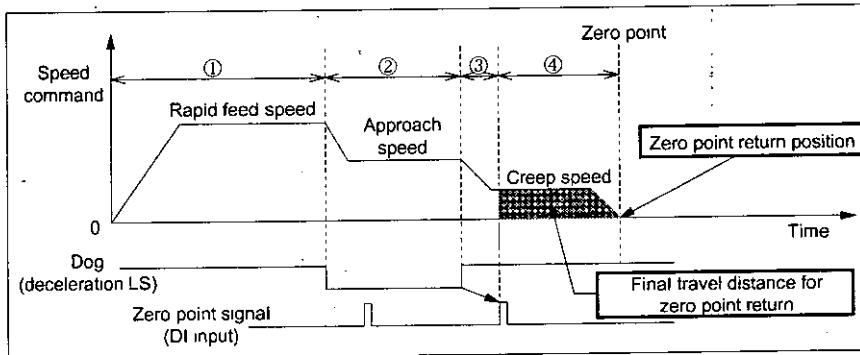

Fig. 3.5 An example of pattern for zero point return (DEC1 + ZERO signal method)

<Preconditions>

Assume that the initial values of the motion fixed parameter and the motion set parameter are the same as in Section 5.3, "Motion Parameter Setting Example."

<Operation Conditions>

Zero point return is carried out by following the pattern shown in Fig.3.5.

Zero point return method: DEC1 + ZERO signal method

This example uses the first axis of module No.1.

When the module No. or the axis No. is different, refer to Section 1.3, "Module No. and Motion Parameter Register No." to substitute the register No.

Refer to Chapter 5, "Motion Parameters" for the details of the register (OWxxxx) in use.

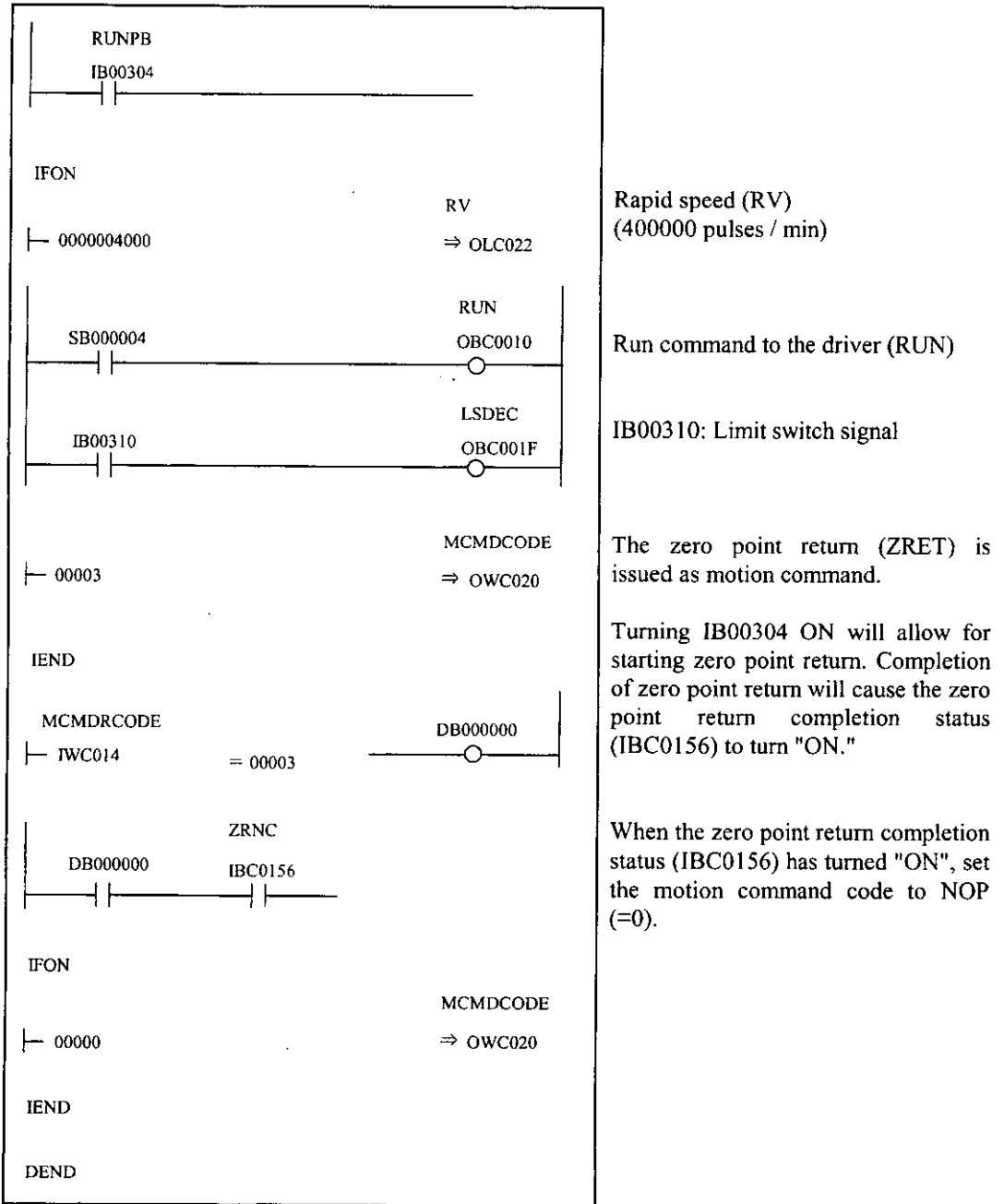

Fig. 3.6 An example of positioning programs (DWG H03)

The example in Fig.3.6 has been simplified, however, each register can be controlled by the user's program as intended.

3.4 Interpolation (INTERPOLATE)

Interpolation feed is performed according to varying position data to be issued by the CPU module.

Fig. 3.9 shows a block diagram. The interpolation feed for each axis is performed as described below. The register No. corresponds to the first axis of module No.1. When the module No. or the axis No. is different, refer to Section 1.3, "Module No. and Motion Parameter Register No." to substitute the register No. For the motion parameter to be used for interpolation feed, a circle "○" is displayed at the "Interpolation" column of the "Motion command code to validate data" in Section 5.1.2, "List of Motion Set Parameters" and in Section 5.1.3, "List of Motion Monitor Parameters."

- ① Set the initial value of the motion fixed parameter and motion set parameter. Set them so as to meet the requirements of the user's machines by means of the Parameter Setting Window of CP-717.
- ② Select the position control mode (PCON) (Bit 2 of OWC000).
* It is recommended to set the initial value at the Parameter Setting Window of CP-717.
- ③ Set the position command setting (OLC012).
If necessary, set such motion set parameters to be used on interpolation (INTERPOLATE) as the filter time constant (OWC014).
- ④ Turn on the Magnetization ON (RUN) (Bit 0 of OWC001).
- ⑤ Set interpolation (INTERPOLATE = 4) to the motion command code (OWC020).
- ⑥ Setting interpolation (INTERPOLATE) to the motion command will allow the axis to perform the interpolation feed according to the designated motion parameters.
- ⑦ Updating the position command (OLC012) is disabled.
- ⑧ Completing the issue (Bit 2 of IWC015 is turned "ON") will cause the completion signal for positioning POSCOMP (Bit D of IWC000) to turn "ON."

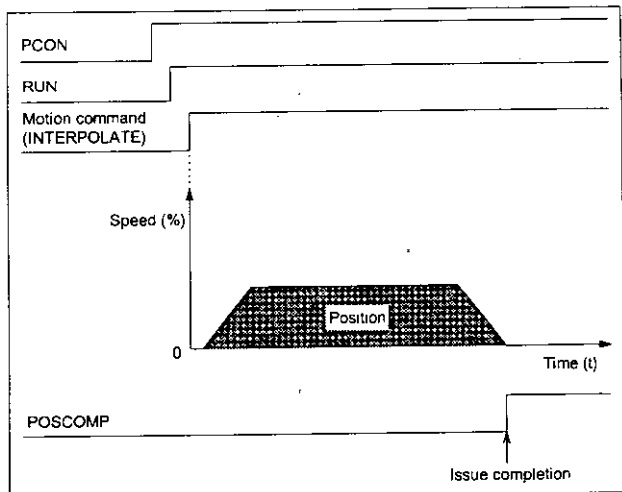
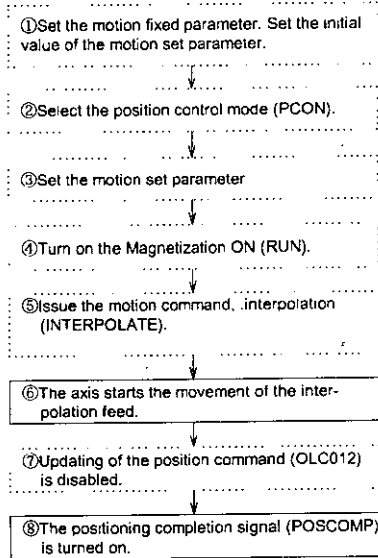

 shows the system in the operating mode.
 shows that the user is required to set.

■ An example of user's programs (Interpolation)

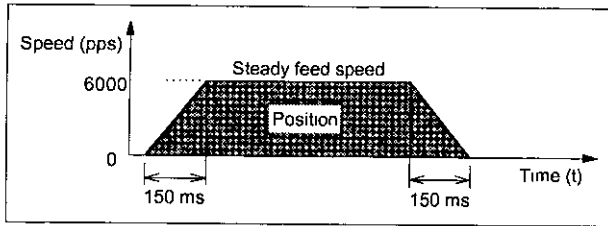

Fig. 3.7 An example of pattern for interpolation

<Preconditions>

Assume that the initial values of the motion fixed parameter and the motion set parameter are the same as in Section 5.3, "Example of Motion Parameter Setting."

<Operation Conditions>

The axis is stopped following the pattern shown in Fig.3.7.

Set value for high-speed scan : 5.0 ms

Steady feed speed = 6000 pulses/s (30 pulses per one scan)

Acceleration/deceleration time constant until the speed reaches the steady feed speed = 150 ms

This example uses the first axis of module No.1.

When the module No. or the axis No. is different, refer to Section 1.3, "Module No. and Motion Parameter Register No." to substitute the register No.

Refer to Chapter 5, "Motion Parameters" for the details of the register (OW_{xxxx}) in use.

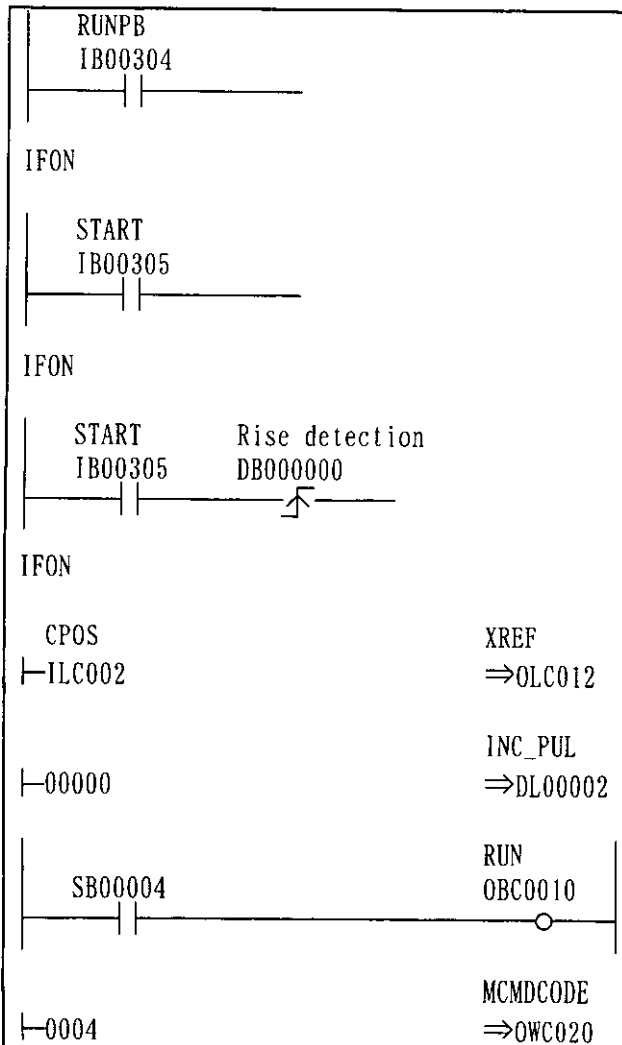

Turning ON IB00304 will start the interpolation feed.

Turning ON IB00305 will start the interpolation feed (acceleration).

(1) Processing at the time of the rise of IB00305
 Detecting the rise of IB00305 will initialize the current position (ILC002) with the position command (OLC012), and also it initializes the number of acceleration /deceleration pulses (DL00002) (=0).

Run command to the driver (RUN)

Interpolation (INTERPOLATE) is issued as motion command.

ELSE			(2) Processing at the time of IB00305 being "ON"
INC_PUL		INC_PUL	The number of acceleration/deceleration pulses (DL00002) is added by one (+1) for every scan.
DL00002	++00001	⇒DL00002	
INC_PUL			When the number of acceleration/deceleration pulses (DL00002) exceeds the steady feed speed (= 30 pulses), a limit is issued with 30 pulses.
DL00002	≧00030		
IFON			
		INC_PUL	
00030		⇒DL00002	
IEND			
XREF	INC_PUL	XREF	
OLC012	++DL00002	⇒OLC012	The position command is updated for every scan (acceleration).
IEND			
ELSE			
INC_PUL		INC_PUL	(3) Processing at the time of IB00305 being "OFF"
DL00002	--00001	⇒DL00002	Turning IB00305 OFF will allow for a decelerating to stop.
INC_PUL			The number of acceleration/deceleration pulses (DL00002) is subtracted by one (-1) for every scan, and the axis stops when the number becomes zero.
DL00002	≦0		
IFON			
		INC_PUL	
00000		⇒DL00002	
IEND			
XREF	INC_PUL	XREF	
OLC012	++DL00002	⇒OLC012	The position command is updated for every scan (deceleration).
IEND			
ELSE			
		MCMDCODE	
00000		⇒0WC020	
IEND			(4) Processing at the time of IB00304 being "OFF"
DEND			Turning IB00304 OFF will release the interpolation feed.

Fig. 3.8 An example of interpolation feed programs (DWG H03)

The example in Fig.3.8 has been simplified, however, each register can be controlled by the user's program as intended.

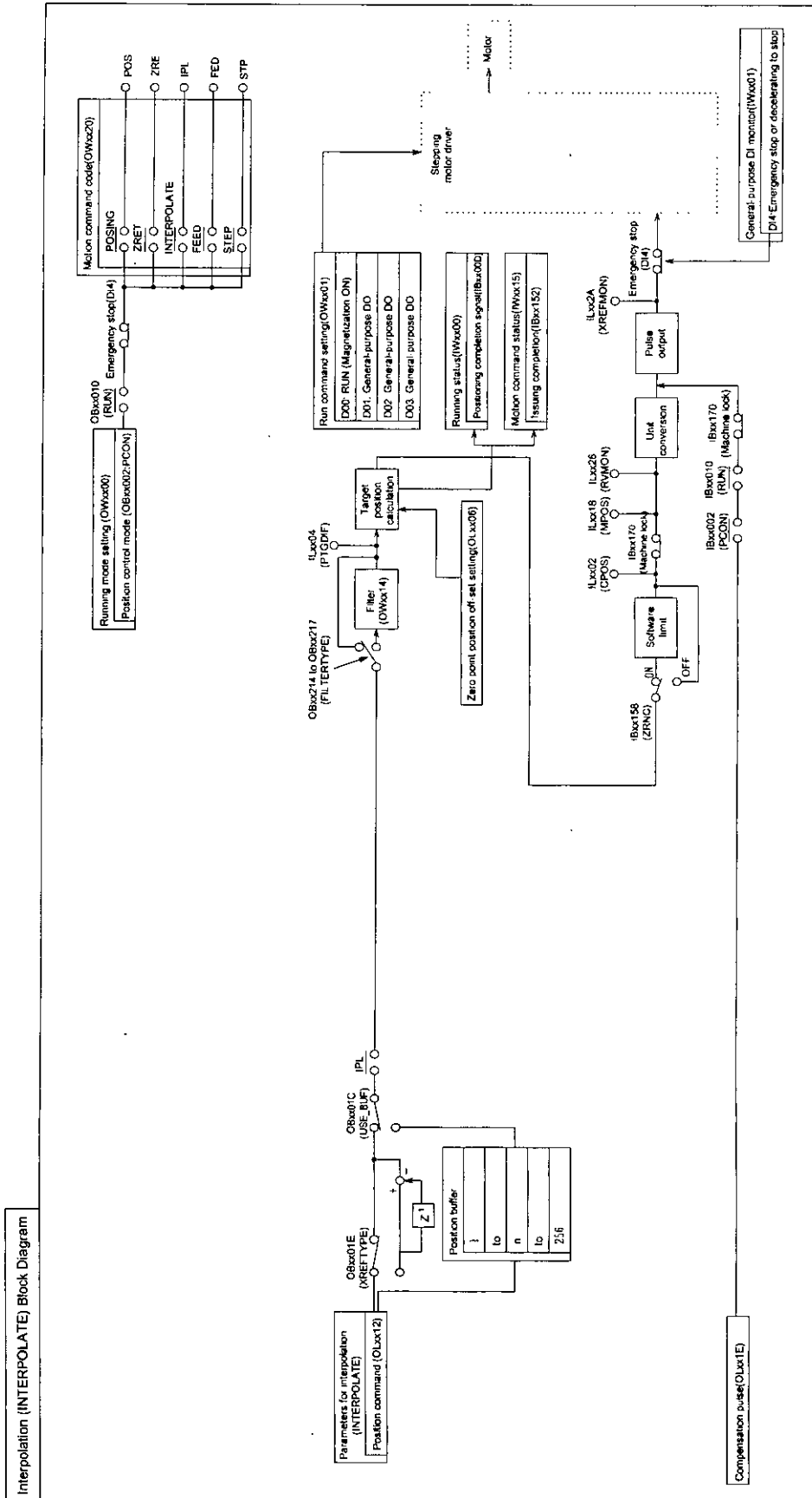

Fig. 3.9 Interpolation (INTERPOLATE) Block Diagram

3.5 Constant Speed Feed (FEED)

Rapid feed is performed with a designated acceleration/deceleration time constant and at rapid speed designated for infinite distance. Rapid speed can be changed even during running. Setting NOP (=0) to the motion command code (OWxx20) will cause the axis to decelerate to stop.

Fig. 3.12 shows a block diagram. The constant speed feed for each axis is performed as described below. The register No. corresponds to the first axis of module No.1. When the module No. or the axis No. is different, refer to Section 1.3, "Module No. and Motion Parameter Register No." to substitute the register No. For the motion parameter to be used for Constant speed feed, a circle "○" is displayed at the "Constant speed feed" column of the "Motion command code to validate data" in Section 5.1.2, "List of Motion Set Parameters" and in Section 5.1.3, "List of Motion Monitor Parameters."

- ① Set the initial value of the motion fixed parameter and motion set parameter. Set them so as to meet the requirements of the user's machines by means of the Parameter Setting Window of CP-717.
- ② Select the position control mode (PCON) (Bit 2 of OWC000).
* It is recommended to set the initial value at the Parameter Setting Window of CP-717.
- ③ Set the rapid feed speed (OLxx22 or OWC015).
If necessary, set such motion set parameters to be used on constant speed feed (FEED) as the linear acceleration/deceleration time constant (OWC00C, OWC00D) and the filter time constant (OWC014).
- ④ Turn on the Magnetization ON (RUN) (Bit 0 of OWC001).
- ⑤ Set the constant speed feed (FEED = 7) to the motion command code (OWC020).
- ⑥ Setting the constant speed feed (FEED) to the motion command will allow the axis to perform the rapid feed movement according to the designated parameters.
The rapid feed cannot be suspended.
- ⑦ To suspend (abort) the rapid feed, set NOP (=0) to the motion command code.
- ⑧ Completing the issue (Bit 2 of IWC015 is turned "ON") causes the completion signal for positioning POSCOMP (Bit D of IWC000) to turn "ON."

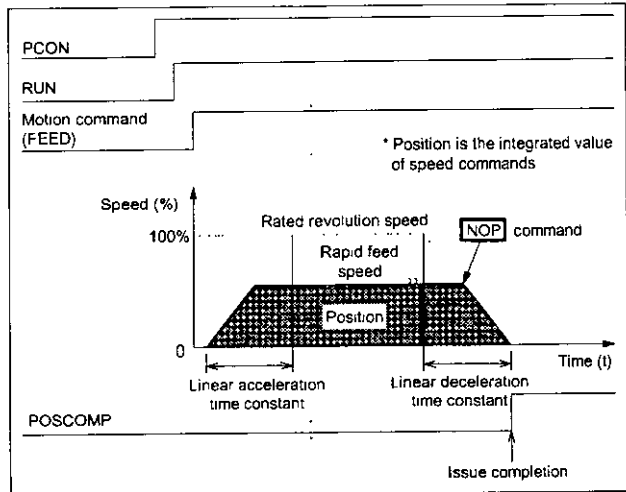
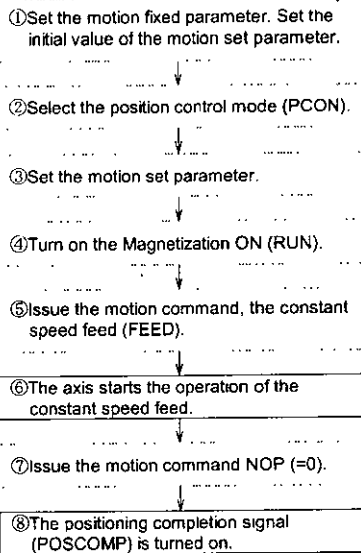

shows the system in the operating mode.
 shows that the user is required to set.

■ An example of user's programs (Constant speed feed)

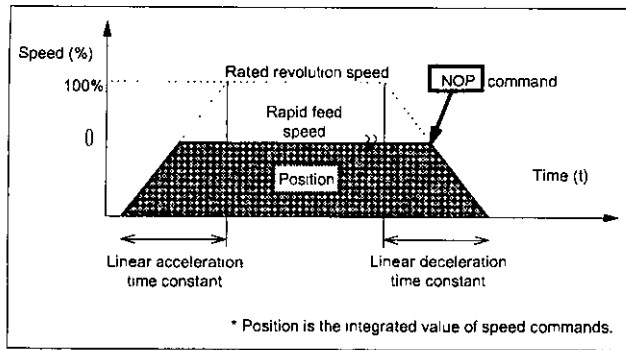

Fig.3.10 An example of pattern for constant speed feed

<Preconditions>

Assume that the initial values of the motion fixed parameter and motion set parameters are the same as in Section 5.3, "Motion Parameter Setting Example."

<Operation Conditions>

In the pattern shown in Fig.3.10, let the rapid feed speed = (400000 pulses/min).

Rapid feed speed : OLC022 = 4000 (1=100 pulses / min)

This example uses the first axis of module No.1.

When the module No. or the axis No. is different, refer to Section 1.3, "Module No. and Motion Parameter Register No." to substitute the register No.

Refer to Chapter 5, "Motion Parameters" for the details of the register (OWxxxx) in use.

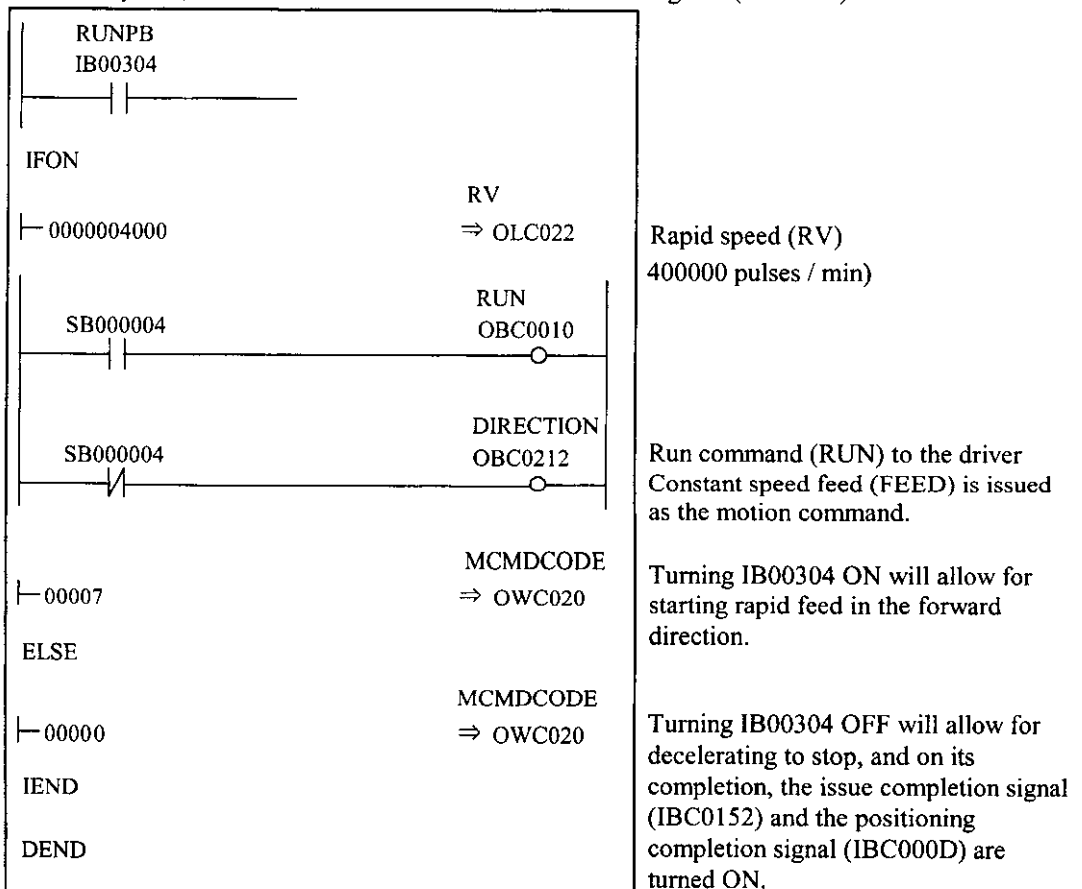

Fig. 3.11 An example of constant speed feed programs (DWG H03)

The example in Fig.3.11 has been simplified, however, each register can be controlled by the user's program as intended.

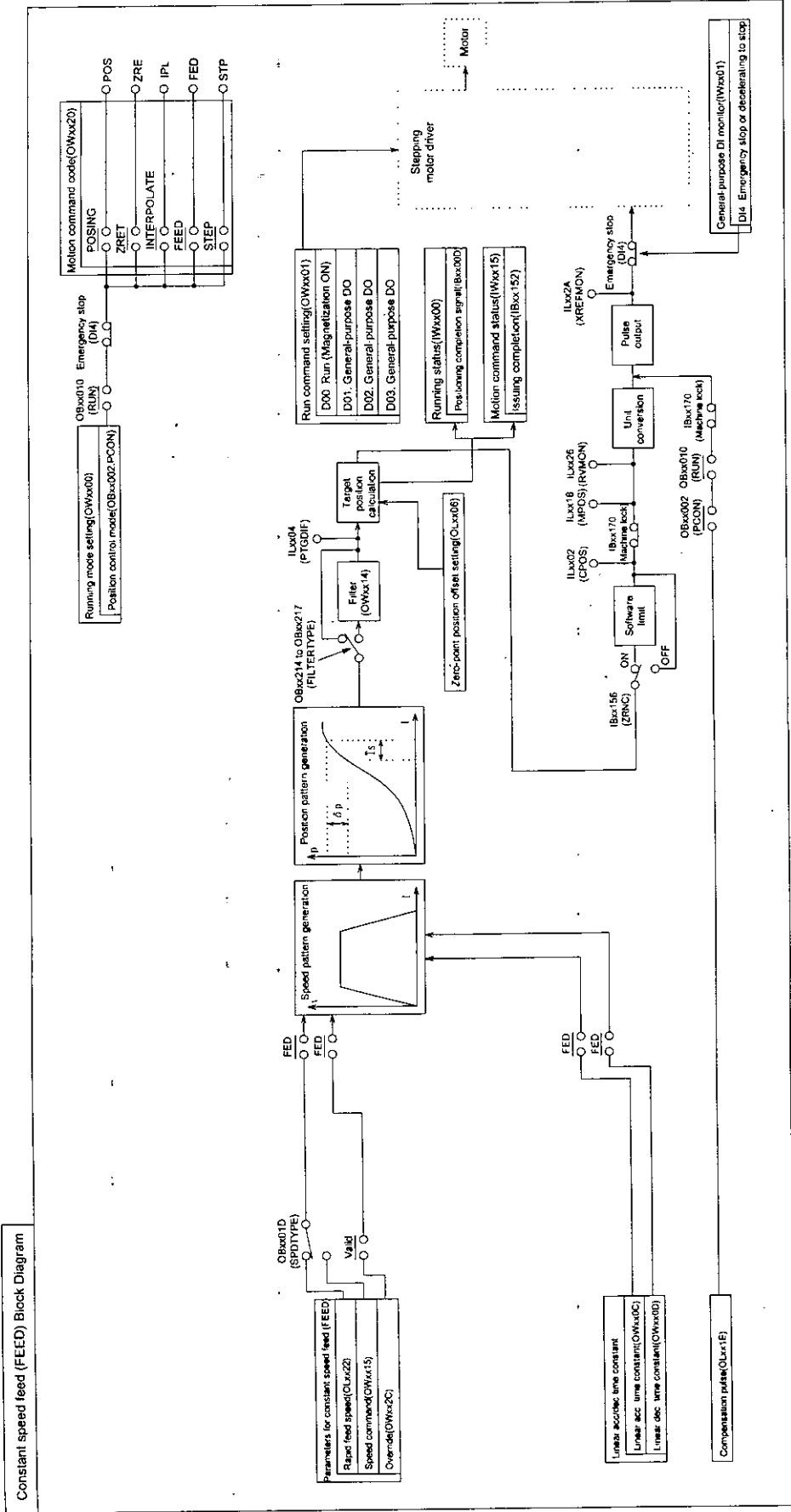

Fig. 3.12 Constant speed feed (FEED) Block Diagram

3.6 Constant Step Feed (STEP)

Positioning is performed at rapid speed by the designated step of movement (by amount of STEP movement) with the designated acceleration/deceleration time constant in the designated direction). Rapid feed speed can be changed even during operation. When the movement step is changed during operation, however, the changed value is reflected on the subsequent execution of constant step feed (STEP).

A block diagram is shown in Fig. 3.15. The constant step feed for each axis is performed as described below. The register No. corresponds to the first axis of module No.1. When the module No. or the axis No. is different, refer to Section 1.3, "Module No. and Motion Parameter Register No." to substitute the register No. For the motion parameter to be used for constant step feed, a circle "○" is displayed at the "Constant step feed" column of the "Motion command code to validate data" in Section 5.1.2, "List of Motion Set Parameters" and in Section 5.1.3, "List of Motion Monitor Parameters."

- ① Set the initial value of the motion fixed parameter and motion set parameter. Set them so as to meet the requirements of the user's machines by means of the Parameter Setting Window of CP-717.
- ② Select the position control mode (PCON) (Bit 2 of OWC000).
* It is recommended to set the initial value at the Parameter Setting Window of CP-717.
- ③ Set the amount of STEP movement (OLC028) and the rapid feed speed (OLC022 or OWC015).
If necessary, set such motion set parameters to be used on constant step feed (STEP) as the linear acceleration/deceleration time constant (OWC00C, OWC00D) and the filter time constant (OWC014).
- ④ Turn on the Magnetization ON (RUN) (Bit 0 of OWC001).
- ⑤ Set the constant step feed (STEP = 8) to the motion command code (OWC020).
- ⑥ Setting the constant step feed (STEP) to the motion command will cause the axis to perform positioning with the designated motion parameters. To suspend positioning, turn HOLD (Bit 0 of OWC021) on. HOLDL (Bit 1 of IWC015) is turned "ON" on completing the suspension. To release it, turn HOLD (Bit 0 of OWL021) "OFF."
To abort positioning, turn ABORT (Bit 1 of OWC021) on. The BUSY (Bit 0 of IWC015) is kept "ON" during the abortion and turned "OFF" on completing the abortion.
(Note) On completion of the abortion, releasing the abortion (turning ABORT "OFF") will result in keeping stopped.
- ⑦ Completing the issue (Bit 2 of IWC015 is turned "ON") will cause the completion signal for positioning POSCOMP (Bit D of IWC000) to turn "ON."
- ⑧ Release the constant step feed of the motion command code when the positioning has been completed.
(Note) The rise is detected for the constant step feed. Therefore, once the constant step feed is executed, it is necessary to set the motion command code to NOP for one scan or more and then set the constant step feed to the motion command code again

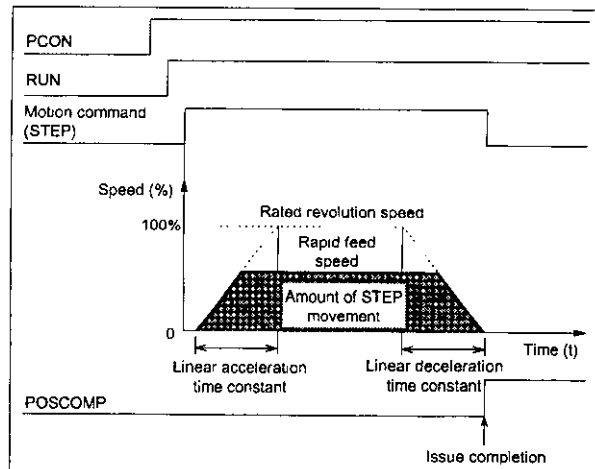
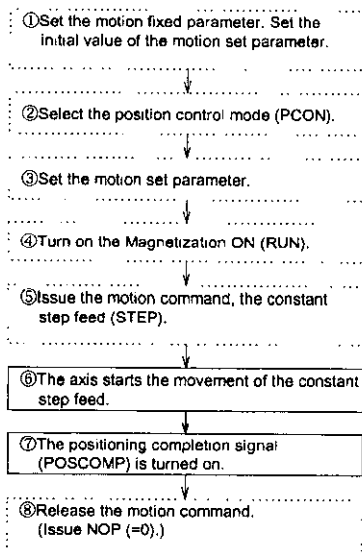

□ shows the system in the operating mode.
 □ shows that the user is required to set.

■ An example of user's programs (Constant step feed)

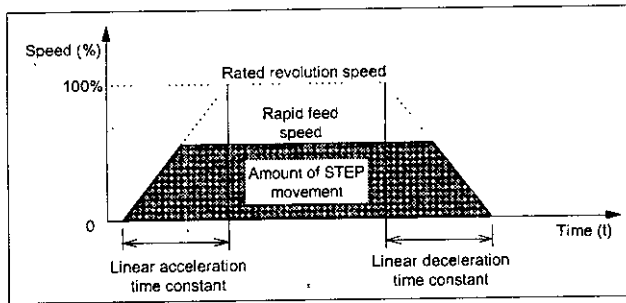

Fig. 3.13 An Example of Pattern for Constant Step Feed

<Preconditions>

Assume that the initial values of the motion fixed parameter and the motion set parameter are the same as in Section 5.3, "Motion Parameter Setting Example."

<Operation Conditions>

In the pattern shown in Fig.3.13, the axis will stop at an amount of STEP movement of 2000 pulses.

The amount of STEP movement : OLC028 = 2000 pulses

This example uses the first axis of module No.1.

When the module No. or the axis No. is different, refer to Section 1.3, "Module No. and Motion Parameter Register No." to substitute the register No.

Refer to Chapter 5, "Motion Parameters" for the details of the register (OWxxxx) in use.

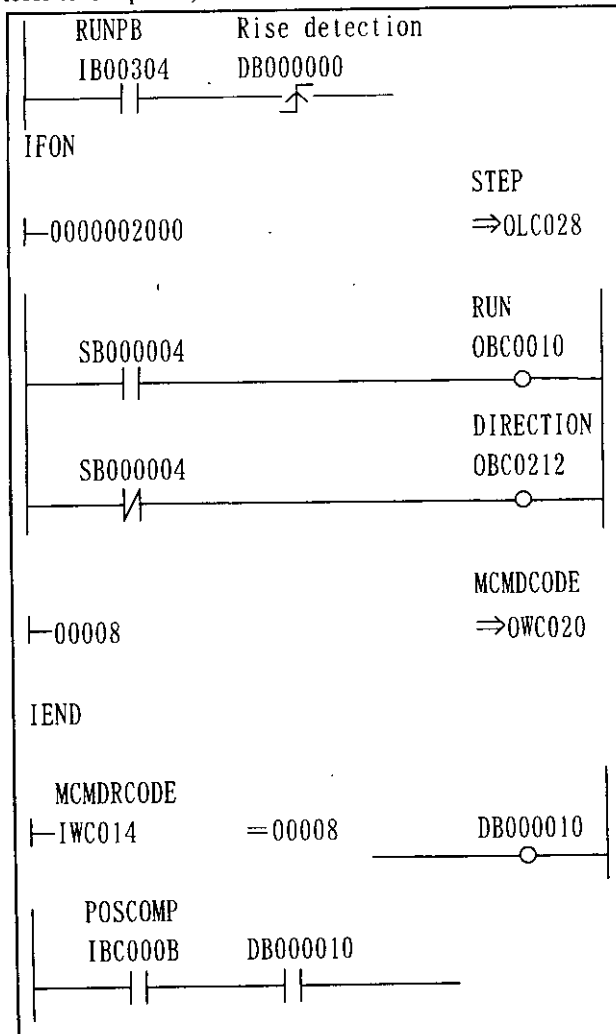

```
IFON
├ 00000      :      MCMDCODE
                ⇒0WC020
IEND
DEND
```

Fig. 3.14 An example of constant step feed programs (DWG H03)

The example in Fig.3.14 has been simplified, however, each register can be controlled by the user's program as intended.

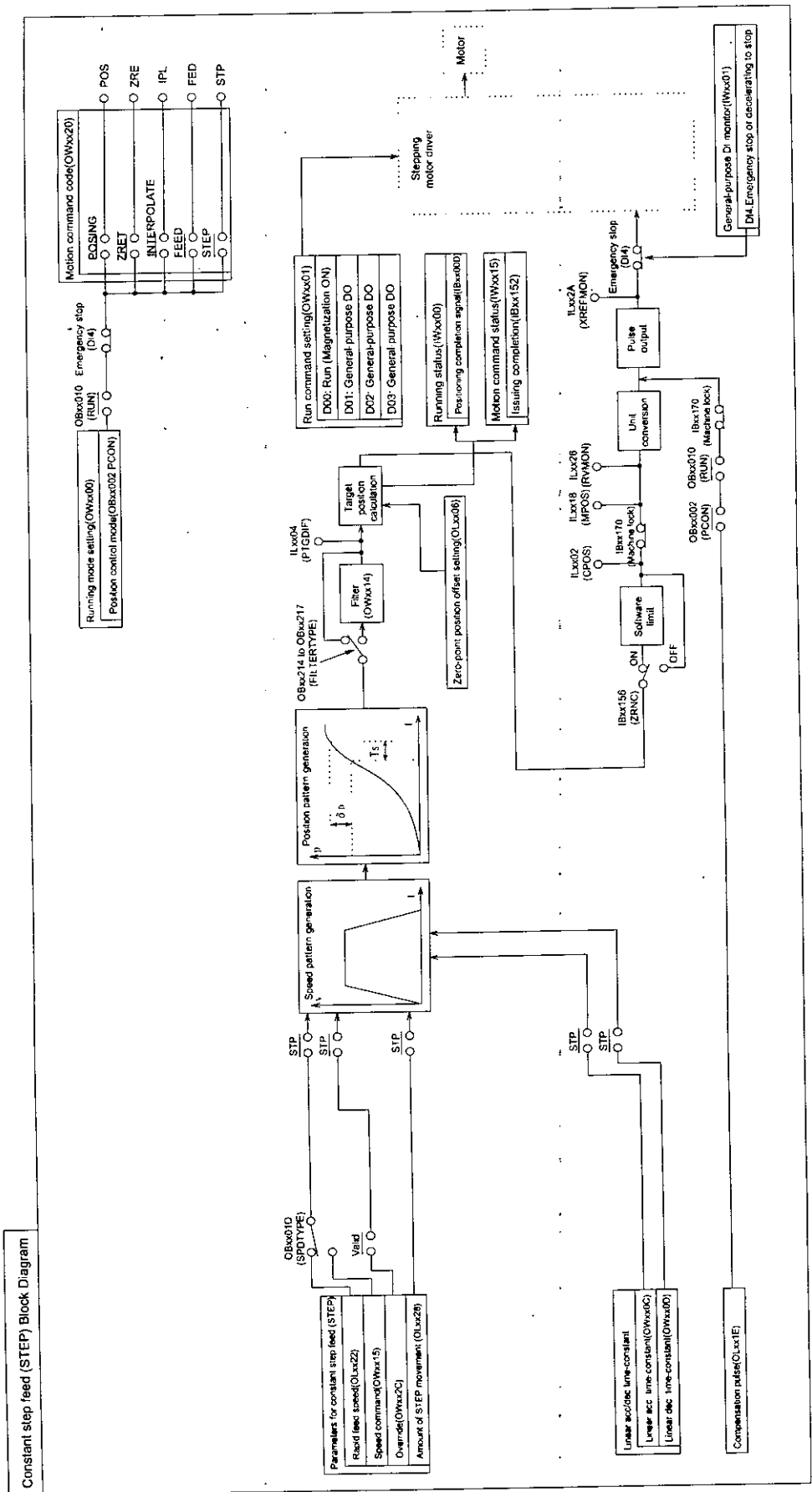

Fig. 3.15 Constant step feed (STEP) Block Diagram

3.7 Zero Point Setting (ZSET)

Executing "Zero point setting" will cause the position to be taken as the "Machine coordinate zero point." Therefore, the zero point can be set without the operation of zero point return.

To use the software limit check, make it sure to execute the operation of zero point return or "Zero point setting."

Perform "Zero point setting" as follows.

- ① Move the machine to the zero point by the constant speed feed, constant step feed, or manual operation.
- ② Set the zero point setting ("9") to the motion command code (OWxx20).
(Note) The position control mode (Bit 2 of OWxx00) and magnetization ON (Bit 0 of OWxx01) may be "ON" or "OFF."
- ③ On completing the zero point setting, the zero point setting completion (Bit 3 of IWxx15) and the zero point return completion status (Bit 6 of IWxx15) are turned "ON."
- ④ When the zero point setting completion is turned "ON," reset the zero point setting of motion command code. (Set the motion command code to NOP (=0)).



CAUTION

The "Zero point setting (ZSET)" is a command for setting the "Machine coordinate zero point." Therefore, incorrect position setting at the "Zero point setting" will result in a movement operation different from an actually intended one in subsequent operation. Before running the machine, make sure to check that the "Machine coordinate zero point" has been correctly set. Caution should be fully taken because skipping this check may lead to a damage of tools due to interference and possible injury.

3.8 Detection of Step-out

Step-out detection is performed by preparing an application program at DWG.Hxx using the counter module (CNTR-01) of CP-9200SH/CP-317.

An example of the module configuration is shown in Fig. 3.16.

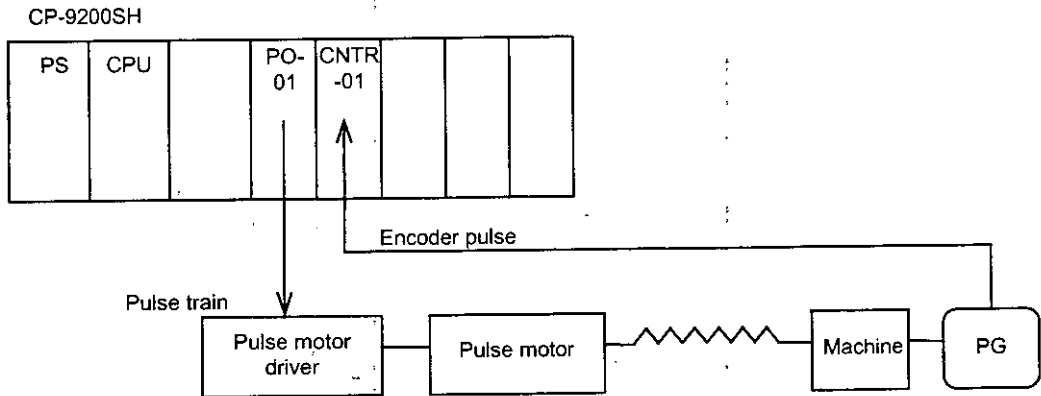

Fig. 3.16 An Example of Module Configuration for Step-out Detection

3.8.1 Outline

Step-out detection is carried out in such a way that the counter value (FB position: N_i) of the counter module (CNTR-01) is converted to the position command (feedback calculation position: P_i) for the pulse motor and the difference between the calculated result (P_i) and command position (M_i) is computed.

The feedback calculated position (P_i) is calculated not by the counter value itself of the CNTR-01 module but by the incremental number of pulses at every scan to correspond to the positioning in the case of infinite distance.

Command position: $M_i = M_{i-1} + \text{the number of output pulses of one scan (ILxx2A of PO-01)}$

FB position: $P_i = P_{i-1} + \frac{\text{The number of incremental pulses of every scan (ILxxx2) \times M + \text{Remainder}}{n \times N}$

N : the number of encoder pulses per one revolution of the motor

M : the number of command pulses per one revolution of the motor

n : a multiple for the number of encoder pulses ($n=1, 2, 4$)

Therefore, when the condition below is satisfied, the machine is regarded as in step-out.

$|M_i - P_i| > \varepsilon$ (ε = deviation allowance : to be set by the user)

To calculate M_i , use the output data of the monitor parameter (the number of output pulses XREFMON : ILxx2A) of the PO-01 module. As for the incremental number of pulses for one scan, use the incremental number of pulses per one scan (PDV: ILxxxx + 2) as the input data for the counter module.

3.8.2 Examples of Application Programs

A step-out detection program is prepared as a high-speed scanning program (DWG.Hxx) using the monitor parameter (the number of output pulses: ILxx2A) of the PO-01 module and the input data (the number of incremental pulses: ILxx02) of the counter module (CNTR-01).

In this example, the first axis of module No.1 of the PO-01 module is used. To use other axis, change the register No. of the parameter (ILC02A) for monitoring.

In addition, it is assumed that the input data of the CNTR-01 module are allocated to IW1000 to IW100F. When the allocation is found to be different, change the register No. of the input data (IL1002). Finally, set the mode of the counter to "Frequency measurement."

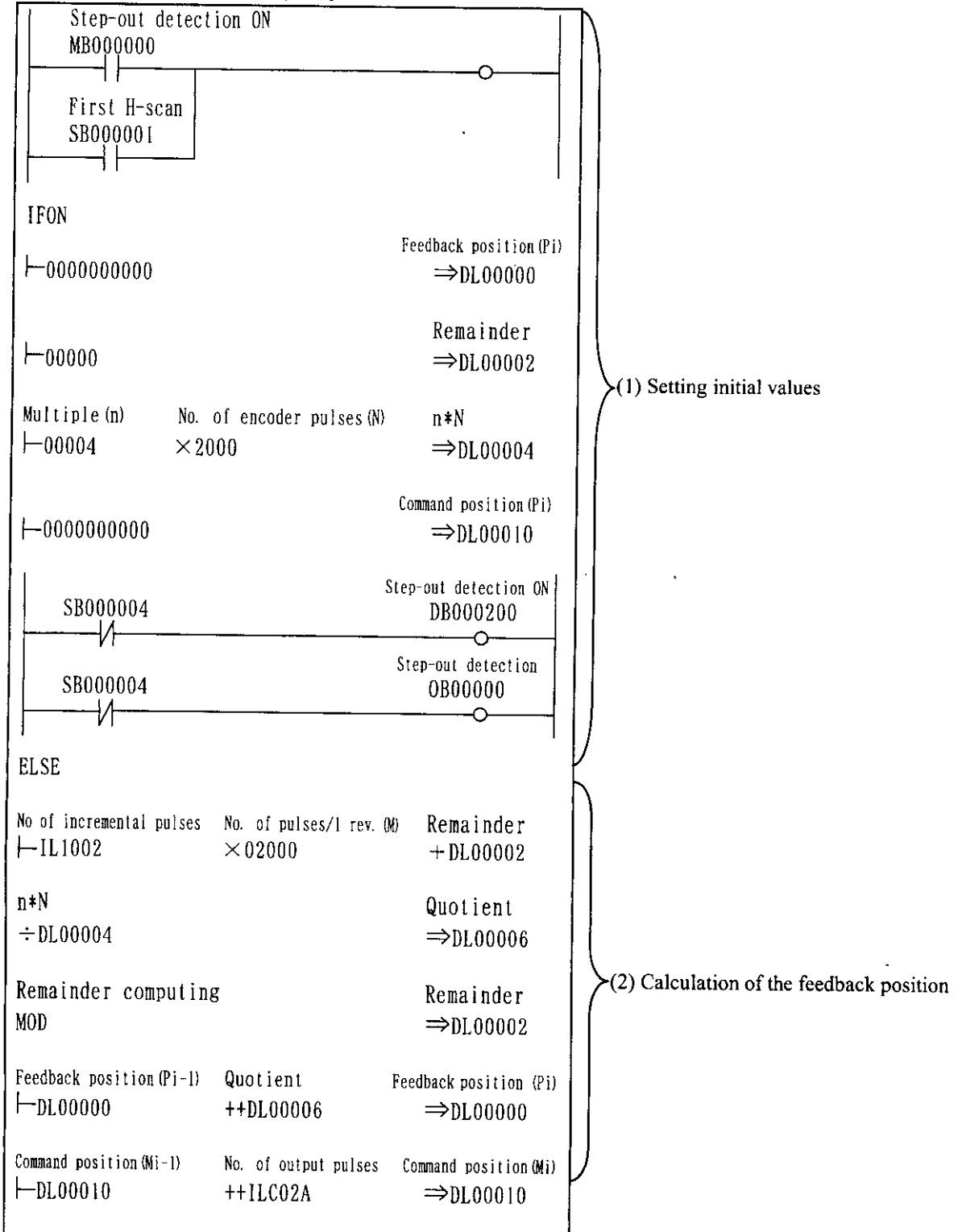

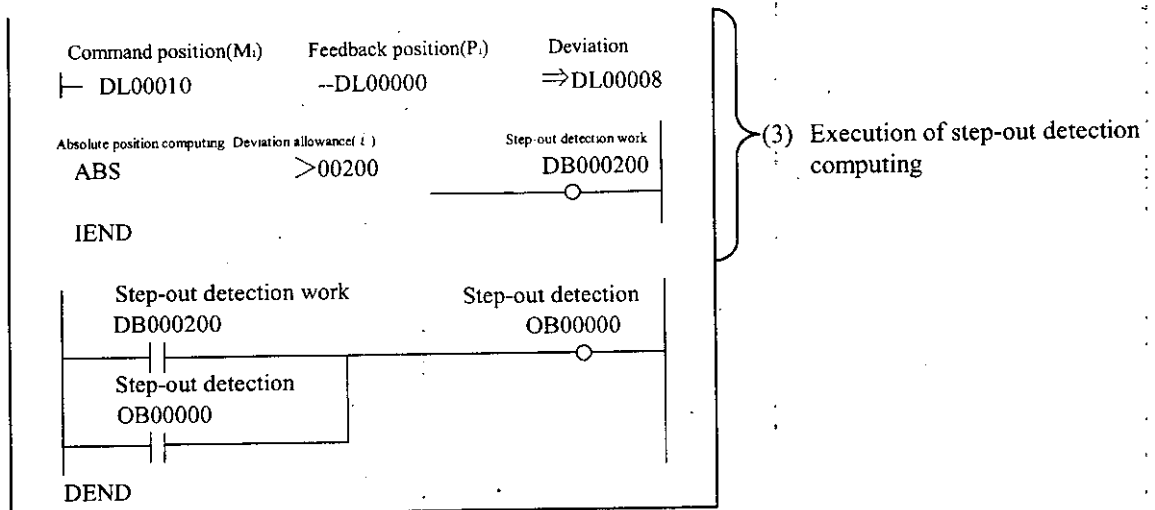

Fig. 3.17 An example of application programs for step-out detection (DWG.H01)

The example of application programs for step-out detection shown in Fig. 3.17 is briefly explained below.

(1) Setting initial values

Set the following initial values when turning off step-out detection (when MB000000 is OFF). Prepare another application program to provide the timing for turning on/off of step-out detection.

Feedback calculation position (DL00000) = 0

Remainder of computing of feedback calculation position (DL00002) = 0

DL00004 = Multiple of encoder pulses (n) × the number of encoder pulses per one revolution of the motor (N)

* In this example, multiple of encoder pulses (n) = 4 and the number of encoder pulses per one revolution of the motor (N) = 2000, however, set them so that they fit to the machine.

Command position (DL00010) = 0

(2) Calculation of feedback position

The feedback calculation position (Pi) can be calculated by the input data of the counter module (the number of pulses for every scan: IL1002), the number of command pulses per one revolution of the motor (M), and the multiple of the number of encoder pulses (n).

$$P_i = P_{i-1} + \frac{\text{The number of incremental pulses of every scan} \times M + \text{Remainder}}{n \times N}$$

* In this example, the number of command pulses per one revolution of the motor (M) = 2000, however, set it so as to fit to the machine.

(3) Execution of step-out detection computing

When the absolute value of the difference between the command position (Mi) and the feedback calculation position (Pi) exceeds the deviation allowance (ε), this is regarded to be step-out and OB00000 is turned ON.

* In this example, the deviation allowance (ε) = 200, however, set it so as to fit to the machine.

<A measure for setting the deviation allowance>

Set 4 times the number of output pulses of one scan when the machine is operated at the rated revolution (rpm).

$$\epsilon = \frac{NR \times \text{The number of command pulses per one revolution of the motor} \times Ts}{600 \times 1000} \times 4$$

NR : Rated revolution (rpm)

Ts : H-scan setting value (ms)

For example, when NR=300 (rpm), the number of command pulses per one revolution of the motor =2000 pulses and Ts = 5 (ms),

$$\epsilon = \{(300 \times 2000 \times 5) \div (60 \times 1000)\} \times 4 = 200$$

3.9 Emergency Stop

The PO-01 module is provided with a special input signal for emergency stop (DI04) for each axis.

There are two methods for emergency stop; one stops the machine immediately by means of hardware, the other decelerates to stop it by means of software, either one can be selected by the motion fixed parameter.

Table 3.13 Parameter for Emergency Stop

Motion fixed parameter	Name	Description
Bit 5 of No. 14	Emergency stop signal selection	<p>Selects the stopping method when the input signal of emergency stop (DI04) is input.</p> <p>0: Emergency stop The machine is immediately stopped by means of hardware.</p> <p>1: Decelerating to stop The machine is decelerated to stop by means of software. The deceleration rate follows the motion set parameter (OWxx0D).</p>

Inputting the input signal for emergency stop (DI04) will lead to a stop according to the stopping method mentioned above and the emergency stop signal/decelerating to stop signal (Bit 4 of IWxx01) of the motion parameter is turned "ON."

When hardware is used for emergency stop, the PO-01 module holds the position data (the position which the PO-01 module controls) at which the emergency stop input signal has been input, however, the position may differ from the actual machine position due to step-out or load resulted from the emergency stop. In this case, release the emergency stop to clear the motion command code and reset the alarm and then carry out zero point return to re-set the position.

Release emergency stop as follows.

- ① Release the emergency stop input signal (DI04).
- ② Turn the magnetization ON (Bit 0 of OWxx01) "OFF."
- ③ Turn the emergency stop/decelerating to stop signal release (Bit 11 of OWxx01) "OFF" → "ON" → "OFF."

(Note) Only releasing the emergency stop input signal (DI04) will not release the emergency stop/decelerating to stop. When the emergency stop/decelerating to stop is released, the emergency stop signal/decelerating to stop signal (Bit 4 of IWxx01) of the motion monitor parameter is turned "OFF."

- ④ Clear the motion command code (OWxx20).
When the emergency stop input signal (DI04) is input during movement of axis, the command abnormal termination status (Bit 5 of IWxx15) is turned "ON." Under this condition, the operation cannot be re-started. Setting "0" to the motion command code (OWxx20) will allow for releasing ("OFF") the command abnormal termination status (Bit 5 of IWxx15).
- ⑤ Turn the alarm clear (Bit 6 of OWxx00) "OFF" → "ON" → "OFF."
When the emergency stop input signal (DI04) is input during movement of the axis, the magnetization OFF alarm (Bit 5 of ILxx22) is turned "ON."
Under this condition, the operation cannot be re-started. Turning the alarm clear (Bit 6 of OWxx00) "OFF" → "ON" → "OFF" will allow for releasing ("OFF") the magnetization OFF alarm (Bit 5 of ILxx22).

Now the re-start of operation is ready. Re-start the operation hereafter according to the ordinary running sequence as follows.

- ⑥ Turn the position control mode (Bit 2 of OWxx00) "ON."
This procedure is not necessary when it has already been turned "ON."
- ⑦ Turn the magnetization ON (Bit 0 of OWxx01) "ON."
- ⑧ Set the zero point return (ZSET) to the motion command code to perform zero point return.
(Note) When the position (CPOS: ILxx02) controlled by the PO-01 module coincides with the actual machine position, this procedure is not necessary.
- ⑨ Execute the ordinary running program.

Note

While the emergency stop signal/decelerating to stop signal (Bit 4 of IWxx01) is "ON," operation is kept stopped. Be sure to release emergency stop as mentioned above.

4 CONTROL BLOCK DIAGRAMS

This chapter provides all control block diagrams to prepare and debug application programs.

PO-01 motion control block diagram

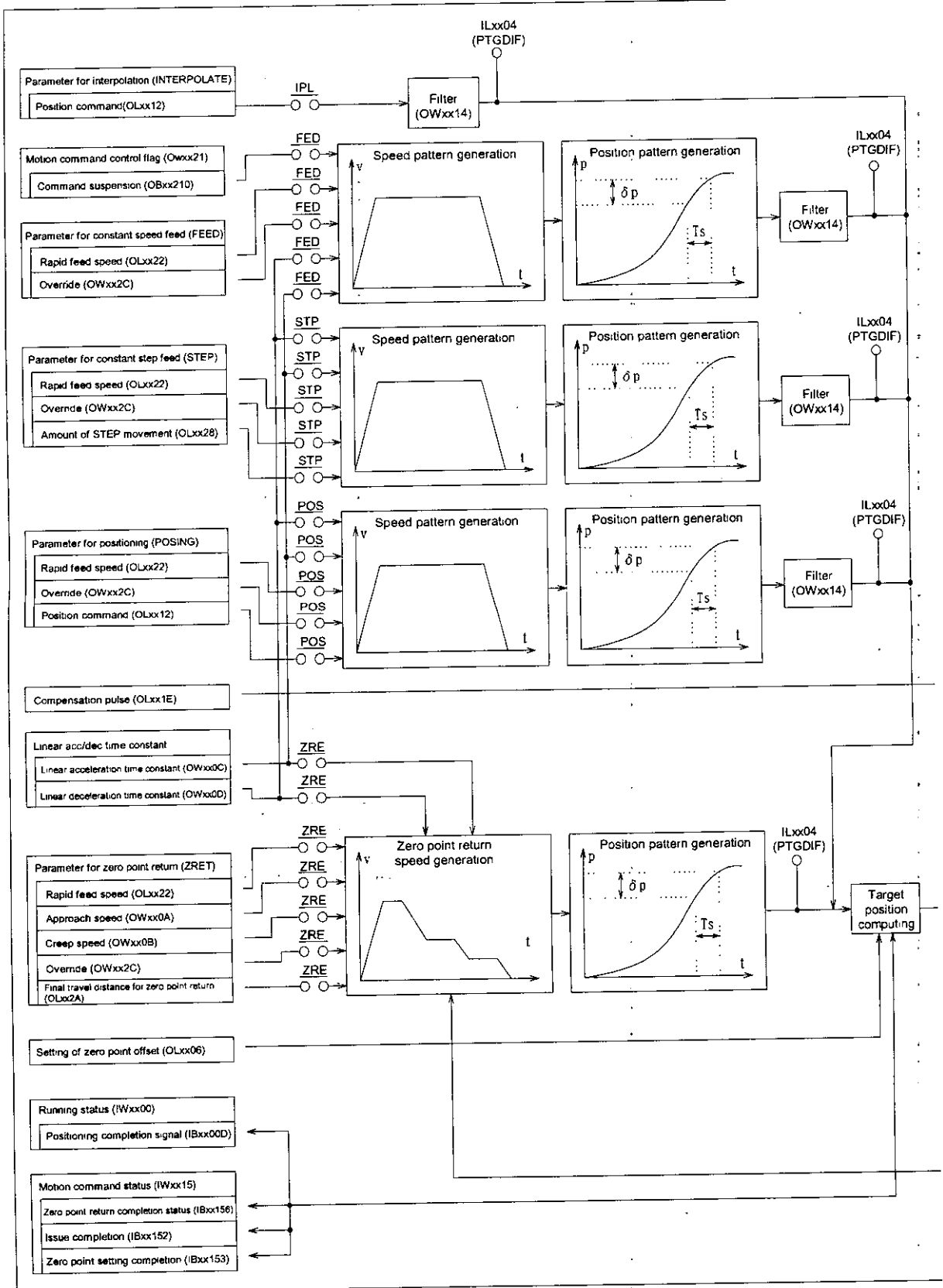

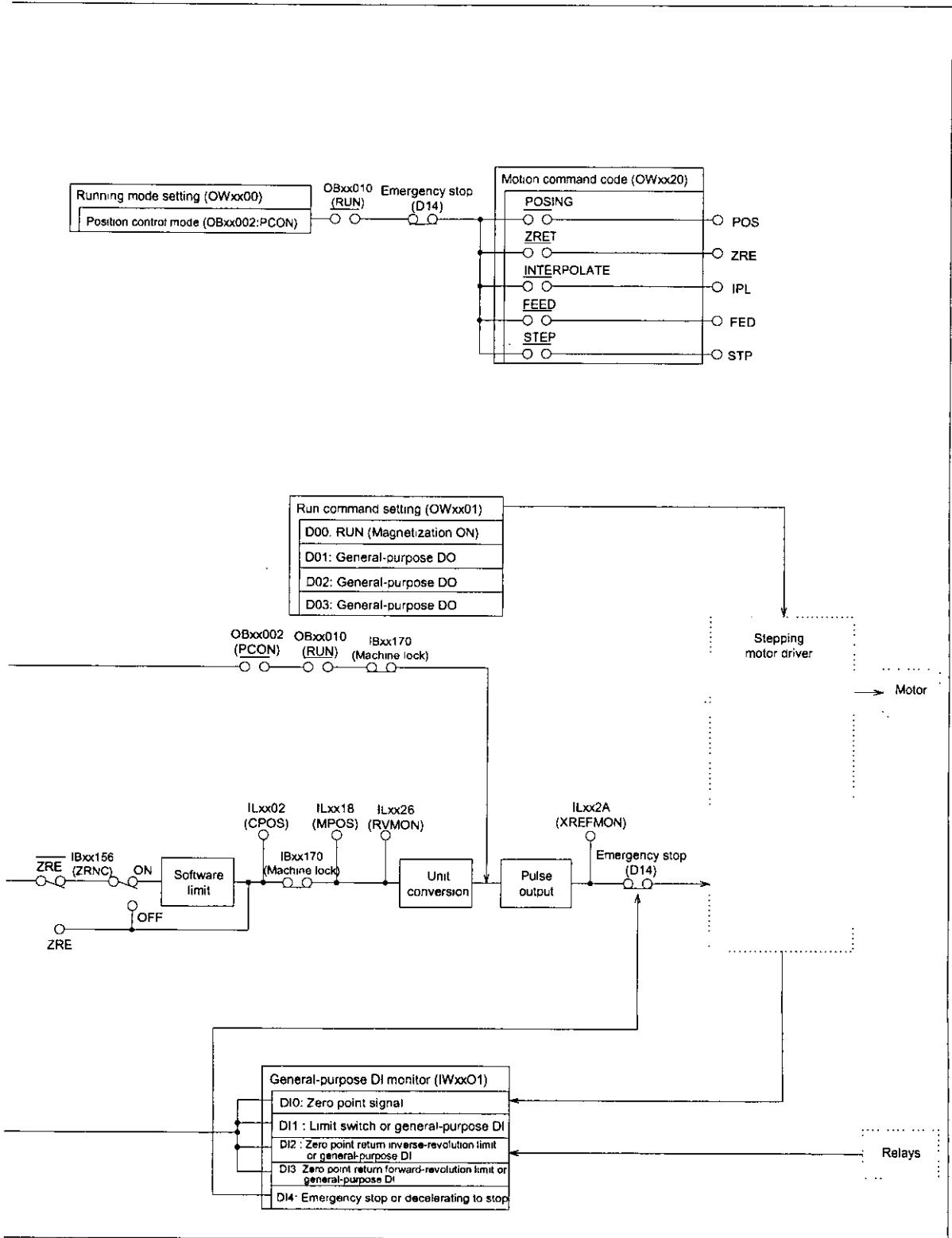

5 MOTION PARAMETERS

 This chapter provides a list of motion parameters with details and setting examples.

5.1 List of Motion Parameters

Each axis is provided with common parameter specifications. The register No. of each axis (1 to 4 axis) is the register No. shown in Tables 5.2 and 5.3 added by axis offset. The axis offset (axis ofs) of each axis is given by $(\text{axis No.} - 1) \times 40\text{H}$ (64 words). The "xx" of the register No. differs depending on the module No. Refer to Section 1.3, "Module No. and Motion Parameter Register No." for details.

All settings are automatically set to defaults when power is turned on. Setting data beyond the setting range to each setting item will result in operation with a value limited by the setting range.

Note

Register numbers are inconsecutive for registers of different module Nos. When module Nos. are the same, registers between axes are consecutive. Therefore, care should be taken when a subscript (i,j) is used in the user's program.

(Example)

For IW(OW)C000i , reading is performed without any error for $i=0$ up to 255. For IW(OW)C000 , the range of registers of module No.1, that is, the range from IW(OW)C000 to IW(OW)C0FF , can be normally read and written. However, reading cannot be correctly performed for $i \geq 256$.

5.1.1 List of Motion Fixed Parameters

These are parameters which will, once set, normally never be changed as long as the configuration or specifications of a machine is not changed. Set them with the "Fixed parameter" tab of the PO-01 Definition Window of the CP-717.

Note

Fixed parameters cannot be changed when the current value of Bit 0 of the setting parameter No.2, "run command setting (OWxx01)," is "ON." Care should be taken because changing the motion fixed parameter will result in initializing position information.

Table 5.1 List of Motion Fixed Parameter

No.	Name	Setting range	Meaning
1	Axis use selection (USESEL)	0 or 1 (Default =0)	0: Select for no use 1: Select for use
2 to 6	Reserved		
7	Rated speed setting (NR)	1 to 32000 (Default =100)	1=1rpm
8 to 13	Reserved		
14	Additional function selection for use (AFUNCSEL)	Bit0: Reserved	
		Bit1: Reserved	
		Bit2: LIMITSEL (Default =0)	Limit switch signal selection 0: OBxx01F for use 1: DI signal for use
		Bit3: LMT_LSEL (Default =0)	Selection of inverse revolution limit-signal for zero point return 0: Obxx21C for use 1: DI signal for use
		Bit4: LMT_RSEL (Default =0)	Selection of forward revolution limit-signal for zero point return 0: Obxx21D 1: DI signal for use
		Bit5: EMGSEL (Default =0)	Selection of emergency stop (DI) signal 0: Emergency stop (hardware) 1: Decelerating to stop (software)
		Bit6: Reserved	
		Bit7: MCMDSEL (Default =1)	Motion command selection for use * Be sure to set "1" to it.
		Bit8: RUNOUTSEL (Default =0)	Magnetization-ON output signal polarity selection 0: Positive logic 1: Negative logic (Valid only for the system software version S0102 or higher)
		Bit9 to 15: Reserved	
15	Reserved		
16	Reserved		
17	Motion controller function selection flag (SVFUNCSEL)	Bit0-3: CMD_UNIT (Default =0)	Command unit selection 0: pulse (Electronic gear invalid) 1: mm 2: deg 3: inch
		Bit4: USE_GEAR (Default =0)	Electronic gear validity selection 0: Invalid 1: Valid
		Bit5: PMOD_SEL (Default =0)	Axis selection 0: Finite length axis 1: Infinite length axis
		Bit6: Reserved	
		Bit7: USE_SLIMP (Default =0)	Software limit (positive direction) validity selection 0: Invalid 1: Valid
		Bit8: USE_SLIMN (Default =0)	Software limit (negative direction) validity selection 0: Invalid 1: Valid
		Bit9: USE_OV (Default =0)	Override validity selection 0: Invalid 1: Valid
		Bit10: INV_DEC (Default =0)	Deceleration LS inverse revolution selection 0: Not 1: Valid
		Bit11 to 15: Reserved	

(to be continued)

Table 5.1 List of Motion Fixed Parameter

(continued)

No.	Name	Setting range	Meaning
18	The number of decimal places (DECNUM)	0 to 5 (Default =3)	Set the number of decimal places of command (Example) For the number of decimal places = 3, mm : One command unit = 0.001 mm deg : One command unit = 0.001 deg inch : One command unit = 0.001 inch This parameter and the command unit selection (See the motion fixed parameter No.17.) gives the minimum command unit. However, the minimum unit of "pulse" is not affected by this parameter.
19	Amount of movement per one revolution of machine (PITCH)	1 to $2^{31}-1$ (Default =10000)	1=1 command unit
21	Gear ratio of the motor side (GEAR_MOTOR)	1 to 65535 (Default =1)	1=1 revolution
22	Gear ratio of the side (GEAR_MACHINE)	1 to 65535 (Default =1)	1=1 revolution
23	Reset position of infinite-length axis (POSMAX)	1 to $2^{31}-1$ (Default =360000)	1=1 command unit
25	Reserved		
27	Software limit value (positive direction) (SLIMP)	-2^{31} to $2^{31}-1$ (Default = $2^{31}-1$)	1=1 command unit
29	Software limit value (negative direction) (SLIMN)	-2^{31} to $2^{31}-1$ (Default = -2^{31})	1=1 command unit
31	Zero point return method (ZRETSEL)	0 to 7 (Default =2)	0: Reserved 1: Reserved 2: DEC1 signal (with switch width) + ZERO signal 3: Reserved 4: DEC2 signal (without switch width) + ZERO signal 5: DEC1 signal (with switch width) + LMT (limit signal for zero point return) + ZERO signal 6: Reserved 7: Reserved
32	Reserved		
33	The number of pulses per one revolution of the motor (MPPS)	1 to $2^{31}-1$ (Default =200)	1=1 pulse (The number of pulses per one revolution of the stepping motor)
35	Bias speed (BIASSPD)	0 to 32767 (Default =0)	$1=10^n$ command unit/min (n: the number of decimal places) For units of pulse: 1=100 pulse/min For units of mm: 1=1mm/min For units of deg: 1=1deg/min For units of inch: 1=1inch/min
36	Bias speed for exponential acceleration/deceleration filter (EXPBIAS)	0 to 32767 (Default =0)	$1=10^n$ command unit/min (n: the number of decimal places) For units of pulse: 1=1000 pulse/min For units of mm: 1=1mm/min For units of deg: 1=1deg/min For units of inch: 1=1inch/min
37	Pulse output signal form selection (POSEL)	Bit0 to 7: Reserved	
		Bit8: ABPOSEL (Default =0)	Pulse output signal polarity selection 0: Positive logic 1: Negative logic
		Bit9 to 11: Reserved	
		Bit12 to 15: POUTMODE (Default =0)	Pulse output method selection 0: CW/CCW method 1: Sign (CCW) + pulse (CW) method
38	Pulse output maximum frequency (MAXHZ)	1 to 50 (Default =10)	$1=10\text{kHz}$ (10 to 500kHz) (10=100kHz) Note: Set one of 1 (10 kHz), 2 (20 kHz), 4 (40 kHz), 5 (50 kHz), 8 (80 kHz), 10 (100 kHz), 20 (200 kHz), 25 (250 kHz), 40 (400 kHz), and 50 (500 kHz). Be sure to set a value common to 4 axes including unused axes.
39 to 48	Reserved		

5.1.2 List of Motion Set Parameters

Parameters are used for commanding the motion module. At the beginning of high-speed scan, the parameters are transferred to the motion module in a batch. Motion control can be performed only by setting the parameters to the register range.



Note

Register numbers are inconsecutive for registers of different module Nos. When module Nos. are the same, registers between axes are consecutive. Therefore, care should be taken when a subscript (i,j) is used in the user's program.

(Example)

For IW(OW)C000i, reading is performed without any error for i=0 up to 255. For IW(OW)C000, the range of registers of module No.1, that is, the range from IW(OW)C000 to IW(OW)C0FF, can be normally read and written. However, reading cannot be correctly performed for $i \geq 256$.

Table 5.2 List of Motion Set Parameters

No.	Name	Register No.	Setting range	Meaning	Motion command code to validate data (OWxx20)					
					Positioning	Zero point return	Interpolation	Constant speed feed	Constant step feed	
1	Run mode setting (RUNMOD)	OWxx00								
		Bit0	Reserved	Set "0."						
		Bit1	Reserved	Set "0."						
		Bit2	PCON (Default =0)	Position control mode		<input type="radio"/>	<input type="radio"/>	<input type="radio"/>	<input type="radio"/>	<input type="radio"/>
		Bit3 to 5	Reserved	Set "0."						
		Bit6	ACR (Default =0)	Alarm clear 1: Alarm clear inquiry		Always valid				
		Bit7	Reserved	Set "0."						
		Bit8	MCDSEL (Default =1)	0: Motion command code (OWxx20) invalid 1: Motion command code (OWxx20) valid * Be sure to set it to "1."		Always valid (for motion function)				
		Bit9	ZRNDIR (Default =0)	Zero point return direction selection 0: Negative (decreasing) direction 1: Positive (increasing) direction						
Bit10 to 15	Reserved	Set "0."								
2	Run command setting (SVRUNCMD)	OWxx01								
		Bit0	RUN (Default =0)	Magnetization ON (DO0)	Always valid					
		Bit1	DO1 (Default =0)	DO1: General-purpose DO						
		Bit2	DO2 (Default =0)	DO2: General-purpose DO						
		Bit3	DO3 (Default =0)	DO3: General-purpose DO						
		Bit4 to 10	Reserved	Set "0."						
		Bit11	EMRST (Default =0)	Releasing emergency stop/decelerating to stop signal		Valid when RUN (Bit 0 of OWxx01) is OFF.				
		Bit12	USE_BUF (Default =0)	Position command value selection 0: Position command value is OLxx12. 1: Position command value position buffer						

(to be continued)

Table 5.2 List of Motion Set Parameters

(continued)

No.	Name	Register No.	Setting range	Meaning	Motion command code to validate data (OWxx20)				
					Positioning	Zero point return	Interpolation	Constant speed feed	Constant step feed
2	Run command setting (SVRUNCMD)	Bit13	SPDTYPE (Default =0)	Speed command value selection 0: OLxx22 is valid for the rapid feed speed. The units of the approach speed (OWxx0A) and creep speed (OWxx0B) are 1 = 10n command unit/min. 1: OLxx15 is valid for the rapid feed speed. The units of the approach speed (OWxx0A) and creep speed (OWxx0B) are 1 = 0.01%	○	○	/	○	○
		Bit14	XREFTYPE (Default =0)	Position command type 0: Absolute position method for position command (OLxx12). 1: Incremental addition method for position command (OLxx12).	○	/	○	/	/
		Bit15	LSDEC (Default =0)	Limit switch signal at zero point return deceleration point	/	○	/	/	/
3 to 6	Reserved	OWxx02 to OWxx05		Set "0."	-----				
7	Machine coordinate zero point offset setting (ABSOFF)	OLxx06	-2^{31} to $2^{31}-1$ (Default =0)	1=1 command unit (1=1 pulse for the pulse unit)	Always valid				
9	Reserved	OLxx08		Set "0."	-----				
11	Approach speed setting (Napr)	OWxx0A	0 to 32767 (Default =0)	The unit differs depending on the speed command value selection (OBxx01D). For the speed command value selection =0, 1=10 ⁿ command unit/min (n: the number of decimal places) For units of pulse: 1=100 pulse/min For units of mm: 1=1mm/min For units of deg: 1=1deg/min For units of inch: 1=1inch/min. For the speed command value selection =1, 1=0.01%(1000=10.00%)	/	○	/	/	/
12	Creep speed setting (Nc1p)	OWxx0B	0 to 32767 (Default =0)	For units of pulse: 1=100 pulse/min For units of mm: 1=1mm/min For units of deg: 1=1deg/min For units of inch: 1=1inch/min. For the speed command value selection =1, 1=0.01%(1000=10.00%)	/	○	/	/	/
13	Linear acceleration time constant (NACC)	OWxx0C	0 to 32767 (Default =0)	1=1ms (300=0.300s)	○	○	/	○	○
14	Linear deceleration time constant (NDEC)	OWxx0D	0 to 32767 (Default =0)	1=1ms (300=0.300s)	○	○	/	○	○
15 to 18	Reserved	OWxx0E to OWxx11		Set "0."	-----				
19	Position reference setting (XREF) or position buffer No.	OLxx12	-2^{31} to $2^{31}-1$ (Default =0)	1=1 command unit (1=1 pulse for the pulse unit) * For position command value selection (OBxx01C)=1, the position buffer No. (1 to 256).	○	/	○	/	/
21	Filter time constant (NNUM)	OWxx14	(1) For Bit 4 through 7 of OWxx21 equal to "2," the S-curve (Moving Average) time constant 0 to 255 (1=1 time) (0=1=without averaging) (Default =0)	○	/	○	○	○	
			(2) For Bit 4 through 7 of OWxx21 equal to "1," the exponential acceleration/deceleration time constant 0 to 32767 (1=1 ms) (Default =0)	○	/	○	○	○	
22	Speed reference setting (NREF)	OWxx15	0 to 32767 (Default =0)	Valid when the speed command value selection (OBxx01D) =1. 1=0.01% (5000=50.00%)	○	○	○	○	○
23 to 30	Reserved	OWxx16 to OWxx1D		Set "0."	-----				

(to be continued)

Table 5.2 List of Motion Set Parameters

(continued)

No.	Name	Register No.	Setting range	Meaning	Motion command code to validate data (OWxx20)					
					Positioning	Zero point return	Interpolation	Constant speed feed	Constant step feed	
31	Offset pulse setting (PULBIAS)	OLxx1E	-2^{31} to $2^{31}-1$ (Default =0)	1=1 pulse	Valid when SVCRUN (IBxx01D) is ON and the machine-lock-ON (IBxx170) is OFF.					
33	Motion command code (MCMDCODE)	OWxx20	0 to 65535 (Default =0)	0: NOP No command available	Always valid					
				1: POSING Positioning						
				2: Reserved						
				3: ZRET Zero point return						
				4: INTERPOLATE Interpolation						
				5: ENDOF_INTERPOLATE Final Interpolation segment						
				6: Reserved						
				7: FEED Constant speed feed						
				8: STEP Constant step feed						
				9: ZSET Zero point setting						
10 to 65535: Reserved										
34	Motion command control flag (MCMDCCTRL)	OWxx21	Bit0	HOLD (Default =0)	Command suspension	<input type="checkbox"/>	<input checked="" type="checkbox"/>	<input checked="" type="checkbox"/>	<input checked="" type="checkbox"/>	<input type="checkbox"/>
			Bit1	ABORT (Default =0)	Command interruption	<input type="checkbox"/>	<input type="checkbox"/>	<input checked="" type="checkbox"/>	<input type="checkbox"/>	<input type="checkbox"/>
			Bit2	DIRECTION (Default =0)	Movement direction 0: Forward 1: Reverse	<input checked="" type="checkbox"/>	<input checked="" type="checkbox"/>	<input checked="" type="checkbox"/>	<input type="checkbox"/>	<input type="checkbox"/>
			Bit3	REMCUT (Default =0)	Selection of no compensation for the remainder of feed speed	<input type="checkbox"/>	<input type="checkbox"/>	<input checked="" type="checkbox"/>	<input type="checkbox"/>	<input type="checkbox"/>
			Bit4 to 7	FILTERTYPE (Default =0)	Filter type selection 0: No filter available 1: Exponential filter (Exponential acceleration/deceleration) 2: Moving average filter (Simple S-curve acceleration/deceleration)	<input type="checkbox"/>	<input type="checkbox"/>	<input checked="" type="checkbox"/>	<input type="checkbox"/>	<input type="checkbox"/>
			Bit8 to 11	Reserved	Set "0."	<input type="checkbox"/>	<input type="checkbox"/>	<input type="checkbox"/>	<input type="checkbox"/>	<input type="checkbox"/>
			Bit12	LMT_L (Default =0)	Reverse revolution limit signal for zero point return Valid only when the fixed parameter No.14, "additional function selection for use" is set to "OBxx21C (setting parameter) in use."	<input checked="" type="checkbox"/>	<input type="checkbox"/>	<input checked="" type="checkbox"/>	<input checked="" type="checkbox"/>	<input checked="" type="checkbox"/>
			Bit13	LMT_R (Default =0)	Forward revolution limit signal for zero point return Valid only when the fixed parameter No.14, "additional function selection for use" is set to "OBxx21D (setting parameter) in use."	<input checked="" type="checkbox"/>	<input type="checkbox"/>	<input checked="" type="checkbox"/>	<input checked="" type="checkbox"/>	<input checked="" type="checkbox"/>
			Bit14	BUF_W (Default =0)	Position buffer write 0: No processing 1: Write	Always valid				
			Bit15	BUF_R (Default =0)	Position buffer read-out 0: No processing 1: Read-out					

(to be continued)

Table 5.2 List of Motion Set Parameters

(continued)

No.	Name	Register No.	Setting range	Meaning	Motion command code to validate data (OWxx20)				
					Positioning	Zero point return	Interpolation	Constant speed feed	Constant step feed
35	Rapid feed speed (RV)	OLxx22	0 to $2^{31}-1$ (Default =0)	1= 10^n command unit/min (n: the number of decimal places) For units of pulse: 1=100 pulse/min For units of mm: 1=1mm/min For units of deg: 1=1deg/min For units of inch: 1=1inch/min	○	○	/	○	○
37	Reserved	OLxx24		Set "0."	/	/	/	/	/
39	Stopping distance (STOPDIST)	OLxx26	-2^{31} to $2^{31}-1$ (Default =0)	1=1 command unit	/	/	○	/	/
41	Amount of STEP movement (STEP)	OLxx28	0 to $2^{31}-1$ (Default =0)	1=1 command unit	/	/	/	/	○
43	Final travel distance for zero point return (ZRNDIST)	OLxx2A	-2^{31} to $2^{31}-1$ (Default =0)	1=1 command unit	/	○	/	/	/
45	Override (OV)	OWxx2C	0 to 32767 (Default = 10000=100%)	1=0.01%	○	○	/	○	○
46	Position control flag (POSCTRL)	OWxx2D							
		Bit0	MLK (Default =0)	Machine lock mode setting 0: OFF 1: ON	Valid when the issue completion (IBxx152) is ON.				
		Bit1	TPRSREQ (Default =0)	Demand for presetting the number of POSMAX turns 1: Demand ON	Always valid				
		Bit2 to 15	Reserved	Set "0."	-----				
47	Work coordinate system Offset (OFFSET)	OLxx2E	-2^{31} to $2^{31}-1$ (Default =0)	1=1 command unit (For units of pulse: 1=1 pulse)	Always valid				
49	Preset data of the number of POSMAX turns (TURNPRS)	OLxx30	-2^{31} to $2^{31}-1$ (Default =0)	1=1 revolution	Valid when the demand for presetting the number of POSMAX turns (Bit 1 of OBxx2D1) is ON.				
51	Reserved	OWxx32		Set "0."	-----				
52	Zero point position output width (PSETWIDTH)	OWxx33	0 to 65535 (Default =10)	1=1 command unit	Always valid after zero point return has been accomplished.				
53 to 56	Reserved	OWxx34 to OWxx37		Set "0."	-----				
57	Position buffer access No.	OLxx38	1 to 256 (Default =0)	Position buffer access No. (0= Invalid)	Valid when either the position buffer write (OBxx21E) is ON or position buffer read-out (OBxx21F) is ON.				
59	Position buffer data for write	OLxx3A	-2^{31} to $2^{31}-1$ (Default =0)		Valid when either the position buffer write (OBxx21E) is ON.				
61 to 63	Reserved	OWxx3C to OWxx3F		Set "0."	-----				

5.1.3 List of Motion Monitor Parameters

These are parameters to be reported by the motion module. They are reported at the head of high-speed scan in a batch. These parameters are also applied for application control and debugging user's programs.

Note

Register numbers are inconsecutive for registers of different module Nos. When module Nos. are the same, registers between axes are consecutive. Therefore, care should be taken when a subscript (i, j) is used in the user's program.

(Example)

For $IW(OW)C000i$, reading is performed without any error for $i=0$ up to 255. For $IW(OW)C000$, the range of registers of module No.1, that is, the range from $IW(OW)C000$ to $IW(OW)C0FF$, can be normally read and written. However, reading cannot be correctly performed for $i \geq 256$.

Table 5.3 List of Motion Monitor Parameters

No.	Name	Register No.	Setting range	Meaning	Motion command code to validate data (OWxx20)				
					Positioning	Zero point return	Interpolation	Constant speed feed	Constant step feed
1	Run status (RUNSTS)	IWxx00			Always valid				
		Bit0	Reserved						
		Bit1	PRMERR	Motion set parameter setting error					
		Bit2	FPRMERR	Motion fixed parameter setting error					
		Bit3 to 6	Reserved						
		Bit7	SVCRDY	Preparation for the running of motion controller is completed.					
		Bit8	SVCRUN	The motion controller is running.					
		Bit9 to 12	Reserved						
		Bit13	POSCOMP	Positioning completion signal					
2	General-purpose DI monitor (SVSTS)	IWxx01			Always valid				
		Bit0	HW_ZERO/DI0	Zero point signal/General-purpose DI (Use as general-purpose DI except for the time of zero point return.)					
		Bit1	DEC/DI1	Limit switch signal/ General-purpose DI Set at the fixed parameter No.14, "additional function selection for use."					
		Bit2	LMT_L/DI2	Reverse revolution limit signal for zero point return/General-purpose DI Set at the fixed parameter No.14, "additional function selection for use."					
		Bit3	LMT_R/DI3	Forward revolution limit signal for zero point return/General-purpose DI Set at the fixed parameter No.14, "additional function selection for use."					
		Bit4	EMRGNCY (DI4)	Emergency stop signal / Decelerating to stop signal Set at the fixed parameter No.14, "additional function selection for use."					
3	Calculated position of machine coordinate system (CPOS)	ILxx02	-2^{31} to $2^{31}-1$	1=1 command unit For units of pulse, 1=1 pulse. Updating to be performed during machine lock.	Always valid				

(to be continued)

Table 5.3 List of Motion Monitor Parameters

(continued)

No.	Name	Register No.	Setting range	Meaning	Motion command code to validate data (OWxx20)					
					Positioning	Zero point return	Interpolation	Constant speed feed	Constant step feed	
7 to 15	Reserved	IWxx06 to IWxx0E			-----					
16	Parameter number for range overrun occurrence (ERNO)	IWxx0F	1 to 65 101 to 148	Motion set parameter No. Motion fixed parameter No. + 100	Valid when the parameter setting error (Bit 1 or 2 of IWxx00) is ON.					
17 to 20	Reserved	IWxx10 to IWxx13			-----					
21	Motion command response code (MCMDCR CODE)	IWxx14	0 to 65535	Motion command currently under execution (Details are the same as OWxx20.)	Always valid					
22	Motion command status (MCMDCRSTS)	IWxx15			Always valid					
			Bit0	BUSY	Command-under-execution flag	Always valid				
			Bit1	HOLDL	Command suspension completion					
			Bit2	DEN	Issue completion					
			Bit3	ZSET	Zero point setting completion					
			Bit4	Reserved						
			Bit5	FAIL	Command abnormal completion status					
			Bit6	ZRNC	Zero point return completion status					
Bit7 to 15	Reserved									
23	Monitor for the number of decimal places (DECNUMM)	IWxx16	0 to 5	Duplicated data of the fixed parameter No.18, "number of decimal places (DECNUM)." "	Always valid					
24	Position control status (POSSTS)	IWxx17			Always valid					
			Bit0	MLKL						Under machine lock
			Bit1	ZERO						Zero point position
			Bit2	PSET2						Second INP completion (for motion functions) (Interlocked with the issue completion)
			Bit3	Reserved						
			Bit4	TPRSE						Presetting the number of POSMAX turns has been completed.
			Bit5	GEARM						Duplicated data of the fixed parameter No.17, Bit 4 of "electronic gear validity selection."
			Bit6	MODSELM						Duplicated data of the fixed parameter No.17, Bit 5 of "axis selection."
Bit7 to 15	Reserved									
25	Machine coordinate command position (MPOS)	ILxx18	-2^{31} to $2^{31}-1$	1=1 command unit For units of pulse: 1=1 pulse Updating not to be performed during machine lock.	Always valid					
27	Reserved	ILxx1A			-----					
29	POSMAX monitor (PMAXTURN)	ILxx1C	1 to $2^{31}-1$	1=1 command unit Duplicated data of the fixed parameter No.23, "POSMAX."	Always valid					
31	The number of POSMAX turns (PMAXTURN)	ILxx1E	-2^{31} to $2^{31}-1$	1=1 revolution Counted up or down every time the number exceeds POSMAX. (To be initialized to "0" at turning power ON.)	Valid when the infinite length axis is selected at the fixed parameter No.17.					
33	Reserved	ILxx20			-----					

(to be continued)

Table 5.3 List of Motion Monitor Parameters

(continued)

No.	Name	Register No.	Setting range	Meaning	Motion command code to validate data (OWxx20)					
					Positioning	Zero point return	Interpolation	Constant speed feed	Constant step feed	
35	Alarm (ALARM)	ILxx22								Always valid
		Bit0 to 2	Reserved							
		Bit3	SOTF	Positive direction software limit						
		Bit4	SOTR	Negative direction software limit						
		Bit5	SVOFF	Magnetization OFF (The move command is issued when SVCRUN is OFF.)						
		Bit6	Reserved							
		Bit7	DISTOVER	The speed is excessive.						
		Bit8	Reserved							
		Bit9	Reserved							
		Bit10	MODERR	Control mode error (The move command has been issued except for the position control mode.)						
Bit11 to 31	Reserved									
37	Reserved	IWxx24								
38	Reserved	IWxx25								
39	Speed command output value monitor (RVMON)	ILxx26	-2^{31} to $2^{31}-1$	1=1 command unit/H scan (For system use)					Always valid	
41	Position buffer read-out data	ILxx28	-2^{31} to $2^{31}-1$	When the position buffer read-out (OBxx21F) = 1, the position buffer data is duplicated.					Valid when the position buffer read-out (OBxx21F) = 1.	
43	The number of output pulses (XREFMON)	ILxx2A	-2^{31} to $2^{31}-1$	1=1 pulse (For system use)					Always valid	
45	Reserved	ILxx2C								
47	Calculated position of the command coordinate system (POS)	ILxx2E	-2^{31} to $2^{31}-1$	1=1 command unit					Always valid	
49 to 63	Reserved	IWxx30 to IWxx3F								

5.2 Details of Motion Parameters

5.2.1 Details of Motion Fixed Parameters

Note

Fixed parameters cannot be changed when the current value of Bit 0 of the setting parameter No.2, "run command setting (OWxx01)," is ON. Care should be taken because changing the motion fixed parameter will result in initializing position information.

Table 5.4 Details of Motion Fixed Parameters

No.	Name	Description	Default value
1	Axis use selection (USESEL)	Designate either "to use (=0)" or "not to use (=1)" the relevant axis. Selecting "not to use" will result in no control of the axis. And also, the motion monitor parameters (IWxx00 to IWxx3F) are not updated. However, "0" is stored to the running status (IWxx00). When no axis is used, select "not to use" in order to shorten the processing time. The default for this is set to "not to use (=0)." However, be sure to set the pulse output maximum frequency even when no axis is used.	0 (Not for use)
2 to 6	Reserved		0
7	Rated speed setting (NR)	Set the number of revolutions at the rated (100%) revolution in the unit of 1r/min. Set it to fit to the machine (the specification of the motor) to be used. The default value for this is set to 100 r/min.	100
8 to 13	Reserved		0
14	Additional function selection for use (AFUNCSEL)	Provides selection of the type of signals to be used and the function a signal is intended for, etc.	
	Bit0	Reserved	0
	Bit1	Reserved	0
	Bit2	Limit switch signal selection (LIMITSEL)	0 (OBxx01F)
	Bit3	Reverse revolution limit signal selection for zero point return (LMT_LSEL)	0 (OBxx21C)
	Bit4	Forward revolution limit signal selection for zero point return (LMT_RSEL)	0 (OBxx21D)
	Bit5	Emergency stop (DI) signal selection (EMGSEL)	0 (Emergency stop)
	Bit6	Reserved	0
	Bit7	Motion command selection for use	1
	Bit8	Magnetization-ON output signal polarity selection	0: Positive logic 1: Negative logic (Valid only for the system software version S0102 or higher)
	Bit9 to 15	Reserved	0
15	Reserved		0
16	Reserved		0

(to be continued)

Table 5.4 Details of Motion Fixed Parameters

(continued)

No.	Name	Description	Default value
17	Motion controller function selection flag (SVFUNCSEL)	Provides function selection such as invalid/valid of a function.	
	Bit0 to 3	Command unit selection (CMD_UNIT) Select the unit of the command to be input. The units for command available are pulse, mm, deg, and inch. This unit selection and setting of the motion fixed parameter No.18, "number of decimal places" will give a minimum command unit by which this module can be commanded. Also refer to Section 3.1.1, "Command Unit."	0 (Pulse)
	Bit4	Electric gear validity selection (USE_GEAR) Select whether or not to use the function of the electronic gear. Refer to Section 3.1.2, "Electronic Gear," for the electronic gear. This is invalid when the command unit selection is the pulse (=0). In this case, set this selection to invalid (=0).	0 (Invalid)
	Bit5	Axis selection (PMOD_SEL) Select either the finite length axis (=0) or infinite length axis (=1). Refer to Section 3.1.3, "Axis Selection," for the finite length axis/infinite length axis.	0 (Finite length axis)
	Bit6	Reserved	0
	Bit7	Software limit (positive direction) validity selection Select whether or not to use the function of the software limit (forward direction). Setting this selection to invalid (=0) will not allow the software limit (forward direction) to work. When this bit is set to valid (=1) and when zero point return has been accomplished (the zero point return completion status, IBxx156, of the motion monitor parameter is "ON"), the software limit function is valid. This selection is invalid when the axis selection (Bit 5 of the motion controller function selection flag) is set to the infinite length axis (=1). In this case set it to invalid (=0).	0 (Invalid)
	Bit8	Software limit (negative direction) validity selection Select whether or not to use the function of the software limit (negative direction). Setting this selection to invalid (=0) will not allow the software limit (negative direction) to work. When this bit is set to valid (=1) and when zero point return has been accomplished (the zero point return completion status, IBxx156, of the motion monitor parameter is "ON"), the software limit function is valid. This selection is invalid when the axis selection (Bit 5 of the motion controller function selection flag) is set to the infinite length axis (=1). In this case set it to invalid (=0).	0 (Invalid)
	Bit9	Override validity selection (USE_OV) Select whether or not to use the function of the override function. Setting this to invalid (=0) will not allow the override to function. Also refer to Section 3.1.5, "Speed Command." (Note) The override means a function to "change to use" the setting of the feed speed.	0 (Invalid)
Bit10	Deceleration LS reverse revolution selection Select whether or not to use the limit switch signal (the deceleration LS) by reversing it on zero point return. Also refer to Section 3.3, "Zero Point Return."	0 (Not to reverse)	
Bit11 to 15	Reserved	0	
18	Number of decimal places (DECNUM)	Set the number of decimal places of the command unit to be input. This setting and the setting of selection for the command unit (Bit 0 through 3 of the motion controller function selection flag) will give a minimum command unit by which this module can be commanded. Also refer to Section 3.1.1, "Command Unit."	3
19	Amount of movement per one revolution of machine (PITCH)	This is a parameter which represents the amount of movement of the load per one revolution of the load axis. Set the value of the amount of movement of the load divided by the command unit. Refer to Section 3.1.2, "Electronic Gear" for details. Setting the Electronic gear validity selection (Bit 4 of the motion controller function selection flag) to invalid will make it invalid. In this case, set the default value.	10000
21	Gear ratio on the motor side (GEAR_MOTOR)	This is a parameter to set the gear ratio between the motor and load. Set the gear ratio on the motor side to this parameter in the unit of one revolution. Setting the Electronic gear validity selection (Bit 4 of the motion controller function selection flag) to invalid will make it invalid. In this case, set the default value.	1
22	Gear ratio on the machine side (GEAR_MACHINE)	This is a parameter to set the gear ratio between the motor and load. Set the gear ratio on the machine side to this parameter in the unit of one revolution. Setting the Electronic gear validity selection (Bit 4 of the motion controller function selection flag) to invalid will make it invalid. In this case, set the default value.	1

(to be continued)

Table 5.4 Details of Motion Fixed Parameters

(continued)

No.	Name	Description	Default value	
23	Reset position of the infinite length axis (POSMAX)	Setting the axis selection (Bit 5 of the motion controller function selection flag) to the infinite length axis requires the setting of the reset position for one revolution. Setting it to the finite length axis will make it invalid. In this case, set the default value. Also refer to Section 3.1.3, "Axis Selection."	360000	
25	Reserved		0	
27	Software limit value (positive direction) (SLIMP)	Setting the software limit (positive direction) selection (Bit 7 of the motion controller function selection flag) is set to valid, set the software limit value (positive direction). Setting it to invalid will make it invalid. In this case, set the default value. When this bit is set to valid (=1) and when zero point return has been accomplished (the zero point return completion status, IBxx156, of the motion monitor parameter is "ON"), the software limit function is valid. This selection is invalid when the axis selection (Bit 5 of the motion controller function selection flag) is set to the infinite length axis (=1). In this case, set the default value.	$2^{31}-1$	
29	Software limit value (negative direction) (SLIMN)	Setting the software limit (negative direction) selection (Bit 8 of the motion controller function selection flag) is set to valid, set the software limit value (negative direction). Setting it to invalid will make it invalid. In this case, set the default value. When this bit is set to valid (=1) and when zero point return has been accomplished (the zero point return completion status, IBxx156, of the motion monitor parameter is "ON"), the software limit function is valid. This selection is invalid when the axis selection (Bit 5 of the motion controller function selection flag) is set to the infinite length axis (=1). In this case set the default value.	-2^{31}	
31	Zero point return method (ZRETSEL)	Set the zero point return method on zero point return. Refer to Section 3.3, "Zero Point Return" for details.	2 (DEC1+ZERO signal)	
32	Reserved		0	
33	The number of pulses per one revolution (MPPS)	Set the number of command pulses per one revolution of the pulse motor. Set this parameter to the specifications of the pulse motor and pulse motor driver. The default value is 200 pulses/revolution.	200	
35	Bias speed (BIASSPD)	Set the bias speed on linear acceleration/deceleration with bias. Set "0" to use the linear acceleration/deceleration without bias. Refer to Section 1.5.2, "Types of Acceleration and Deceleration" for details.	0	
36	Bias speed for exponential acceleration/deceleration filter (EXPBIAS)	Set the bias speed on exponential acceleration/deceleration with bias. Set "0" to use the exponential acceleration/deceleration without bias. Refer to Section 1.5.2, "Types of Acceleration and Deceleration" for details.	0	
37	Pulse output signal form selection (POSEL)	Set the polarity and method of the output pulse signal of the module.	0	
	Bit0 to 7	Reserved	0	
	Bit8	Pulse output signal polarity selection (ABPOSEL)	By the positive logic (=0) or negative logic (=1), set the polarity of the pulse signal for output to the pulse motor driver by module. Set it to the specifications of the pulse motor driver. Refer to Section 1.4.1, "Command Pulse Form" for details.	0 (positive logic)
	Bit9 to 11	Reserved	0	
	Bit12 to 15	Pulse output method selection (POUTMODE)	Set the output method of the pulse signal for output to the pulse motor driver by the module. Set either the CW/CCW method (=0) or sign method (=1). Set it to the specifications of the pulse motor driver. Refer to Section 1.4.1, "Command Pulse Form" for details.	0 (CW/CCW method)
38	Pulse output maximum frequency (MAXHZ)	Set the maximum frequency of the pulse signal for output to the pulse motor driver by the module. Set it to the specifications of the pulse motor driver. Refer to Section 1.4.1, "Command Pulse Form" for details. Note: Set one of 1 (10 kHz), 2 (20 kHz), 4 (40 kHz), 5 (50 kHz), 8 (80 kHz), 10 (100 kHz), 20 (200 kHz), 25 (250 kHz), 40 (400 kHz), and 50 (500 kHz). Be sure to set a value common to 4 axes including the unused axes.	10 (100kHz)	
39 to 48	Reserved		0	

5.2.2 Details of Motion Set Parameters

Note

Register numbers are inconsecutive for registers of different module Nos. When module Nos. are the same, registers between axes are consecutive. Therefore, care should be taken when a subscript (i,j) is used in the user's program.

(Example)

For IW(OW)C000i, reading is performed without any error for i=0 up to 255. For IW(OW)C000, the range of registers of module No.1, that is, the range from IW(OW)C000 to IW(OW)C0FF, can be normally read and written. However, reading cannot be correctly performed for $i \geq 256$.

Table 5.5 Details of Motion Set Parameters

No.	Name	Register No.	Setting range	Description	Default value
1	Run mode setting (RUNMOD)	OWxx00		Set the running mode such as control mode or alarm reset. The running mode is made up of bits. The configuration of the bits are shown below.	
		Bit0	Reserved	Set "0."	0
		Bit1	Reserved	Set "0."	0
		Bit2	Position control mode (PCON)	Set the position control mode.	0
		Bit3 to 5	Reserved	Set "0."	0
		Bit6	Alarm clear (ACR)	The rise of this bit will clear (=0) error information. The following items are to be cleared: (1) An error in setting the motion set parameter (IBxx001) (2) Alarm (IIX22)	0
		Bit7	Reserved	Set "0."	0
		Bit8	MCDSEL	Set whether or not to use the motion command code (OWxx20). Be sure to set "1" for this module.	1
		Bit9	Selection of direction for zero point return (ZRNDIR)	Set the direction for zero point return on zero point return (DEC1 + ZERO signal). 0: Returns to zero point in the negative direction (in the direction of position pulses to be reduced). 1: Returns to zero point in the positive direction (in the direction of position pulses to be increased). Also refer to Section 3.3, "Zero point return."	0
Bit10 to 15	Reserved	Set "0."	0		
2	Run command setting (SVRUNCMD)	OWxx01		Set the output signal from this module to the pulse motor driver and the running mode necessary for motion control. The run command is made up of bits. The configuration of the bits are shown below.	
		Bit0	Magnetization-ON (RUN)	Used as magnetization-ON signal of the pulse motor driver. Connect DO00 to the magnetization-ON signal of the pulse motor driver. Under the conditions: • SVCRDY (IBxx007) is ON • Position control mode (OBxx02) is ON • Bit0 is "1" 1. If Bit8 of the fixed parameter No. 14 is set to "0 (positive logic)," "1 (Transistor ON)" is output from DO00. 2. If Bit8 of the fixed parameter No.14 is set to "1 (negative logic)," "0 (Transistor OFF)" is output from DO00. When the emergency stop (DI) signal is input, "0 (Transistor OFF)" is output in case of 1, and "1 (Transistor ON)" is output in case of 2. Under the condition that SVCRDY (IBxx007) is OFF, "0 (Transistor OFF)" is output from DO00 in any case. (Valid only for the system software version S0102 or higher)	0
		Bit1	DO1	Available as general-purpose DO. Connect DO01 to an applicable device. DO01 outputs data which has been set to this bit.	0
		Bit2	DO2	Available as general-purpose DO. Connect DO02 to an applicable device. DO02 outputs data which has been set to this bit.	0
		Bit3	DO3	Available as general-purpose DO. Connect DO03 to an applicable device. DO03 outputs data which has been set to this bit.	0
		Bit4 to 10	Reserved	Set "0."	0

(to be continued)

Table 5.5 Details of Motion Set Parameters

(continued)

No.	Name	Register No.	Setting range	Description	Default value
2	Run command setting (SVRUNCMD)	Bit11	Emergency stop/ decelerating to stop signal release (EMRST)	Setting this bit to "1" when the magnetization-ON (OBxx010) is "0" will release (=0) the emergency stop / decelerating to stop signal (IBxx014). When the emergency stop signal (DI04) is input, set the magnetization-ON (OBxx010) to "0" and then be sure to turn this bit OFF → ON → OFF. And also refer to Section 3.9, "Emergency stop."	0
		Bit12	Position command value selection (USE_BUF)	Select the setting location for the position command data. 0: Represents that the position command data are those of OLxx12. The position command data is set to OLxx12. 1: Represents that the position command data are position buffers. The position buffer No. is set to OLxx12. At this time, the position data is required to have been set to the designated position buffer No. Refer to Section 3.1.4, "Position Command" for details.	0
		Bit13	Speed command value selection (SPDTYPE)	Select the register No. and unit of speed command value of the feed speed, approach speed, or creep speed. 0: Set the rapid feed speed to OLxx22. The setting unit of the approach speed (OWxx0A) and creep speed (OWxx0B) is 1=10 ⁿ command unit / min. 1: Set the rapid feed speed to OWxx15. The setting unit of the approach speed (OWxx0A) and creep speed (OWxx0B) is 1=0.01%. Refer to Section 3.1.5, "Speed Command" for details.	0
		Bit14	Position command type (XREFTYPE)	Select the data type of the position command data. 0: The position command (OLxx12) follows the absolute position method. 1: The position command (OLxx12) follows the increment addition method. Refer to Section 3.1.4, "Position Command" for details.	0
		Bit15	Limit switch signal at the deceleration point for zero point return (LSDEC)	Functions as limit switch signal for zero point return operation when the limit switch signal selection of the motion fixed parameter (Bit 2 of the addition function selection) is set to "OBxx01F). Therefore it is necessary to connect (program) an external signal (DI signal taken into by the LIO-01 module, etc.) to OBxx01F using a user's program. Refer to Section 3.3, "Zero point return" for the zero point return operation.	0
3 to 6	Reserved	OWxx02 to OWxx05		Set "0."	0
7	Machine coordinate zero point offset setting (ABSOFF)	OLxx06	-2 ³¹ to 2 ³¹ -1	The position information can be offset only by means of the setting value of this register. This is valid even during RUN, however, use it when RUN is OFF. This register accommodates data which constitutes the position control performed by this module. Any incorrect setting to this register will affect subsequent movement operation so that care must be taken when used. Be sure to check whether correct data have been set or not before running. Failure to check it may lead to tool damage due to interference and possible accidents.	0
9	Reserved			Set "0."	0
11	Approach speed setting (Napr)	OWxx0A	0 to 32767	Used for zero point return. It should be noted that the setting unit differs according to the speed command value selection (OBxx00D). (1) OBxx00D=0 makes 10 ⁿ command unit/min. (2) OBxx00D=1 makes 1=0.01% command unit (the proportion to the rated revolution speed). And also refer to Section 3.1.5, "Speed Command" and Section 3.3, "Zero Point Return."	0
12	Creep speed setting (Nclp)	OWxx0B	0 to 32767		0

(to be continued)

Table 5.5 Details of Motion Set Parameters

(continued)

No.	Name	Register No.	Setting range	Description	Default value
13	Linear acceleration time constant (NACC)	OWxx0C	0 to 32767	Set the linear acceleration time. Set the acceleration time to reach from 0 % to 100 % (the rated revolution speed). Also refer to Section 1.5.2, "Types of Acceleration/Deceleration."	0
14	Linear deceleration time constant (NDEC)	OWxx0D	0 to 32767	Set the linear deceleration time. Set the deceleration time to reach from 100 % (the rated revolution speed) to 0 %. Also refer to Section 1.5.2, "Types of Acceleration/Deceleration."	0
15 to 18	Reserved			Set "0."	0
19	Position reference setting (XREF) or position buffer No.	OLxx12	-2^{31} to $2^{31}-1$	Set the position command value. Care should be taken because the setting data will bear a different meaning according to the position command value selection (OBxx00C) and position command type (OBxx00E). Refer to Section 3.1.4, "Position Command" for details.	0
21	Filter time constant (NNUM)	OWxx14	(1) When the moving average filter is used, 0 to 255 (0=1=without filter). (2) Exponential acceleration/deceleration 0 to 32767	Set the time constant to use the moving average filter or the exponential acceleration/deceleration filter. It should be noted that the setting range differs according to the type of the filter to be used. Set the type of the filter by the filter type selection (Bit 4 to 7 of OWxx21). When the filter time constant is changed, care should be taken because this will become valid at the time of completion of issue (IBxx152 is "ON"). Also refer to Section 1.5.2, "Types of Acceleration/Deceleration."	0
22	Speed reference setting (NREF)	OWxx15	0 to 32767	When the speed command value selection (OBxx01D) is set to "0", set the rapid feed speed in the unit of 0.01 % (the proportion against the rated revolution speed). Also refer to Section 3.1.5, "Speed Command."	0
23 to 30	Reserved			Set "0."	0
31	Offset pulse setting (PULBIAS)	OLxx1E	-2^{31} to $2^{31}-1$	The amount of pulses (1=1 pulse) set to this register is output as compensation pulses when SVCRUN (IBxx008) is "ON" and machine lock ON (IBxx170) is "OFF." The amount of pulses set to this register is output regardless of the position information controlled by this module. This setting is used to compensate the command pulse such as backlash, etc. The amount of pulses set to this register is added to the command pulse to be output at every scan. It should be fully noted because setting a large value to this register may result in step-out.	0
33	Motion command code (MCMDCODE)	OWxx20	0 to 65535	Set the motion function (such as move command) to be used. The motion functions available are Positioning (POSING), Zero point return (ZRET), Interpolation (INTERPOLATE), Constant speed feed (FEED), and Constant step feed (STEP). The final interpolation segment (END_OF_INTERPOLATE) is intended for the motion functions which you do not need to use. Setting the move command by this register when SVCRUN (IBxx008) is "OFF" will result in an alarm. Refer to Sections 3.2, "Positioning" through 3.7, "Zero point Setting" for details.	0

(to be continued)

Table 5.5 Details of Motion Set Parameters

(continued)

No.	Name	Register No.	Setting range	Description	Default value
34	Motion command control flag (MCMDCTRL)	OWxx21	Set a supplementary function of the motion command.		0
		Bit0	Suspension of command (HOLD)	Valid when the motion command (OWxx20) is at the positioning and constant step feed. When this bit is turned ON during the movement of the axis, the axis is decelerated to stop. On completing the suspension, the suspension completion (IBxx151) is turned "ON." When this bit is turned back to "OFF" under this condition, the suspension is released to restart the positioning operation. Refer to the relevant item of each motion function for the suspension.	0
		Bit1	Abortion of command (ABORT)	Valid when the motion command (OWxx20) is at the positioning, zero point return, and constant step feed. When this bit is turned ON during the movement of the axis, the axis is decelerated to stop. BUSY (IBxx150) is turned "ON" during abortion and turned "OFF" at the time of completing abortion. Refer to the relevant item of each motion function for the abortion. To abort the constant speed feed, set the motion command to NOP to allow for the same function.	0
		Bit2	Direction of movement (DIRECTION)	Valid when the motion command (OWxx20) is at constant speed feed and constant step feed. Designate the direction of movement. 0: Forward revolution 1: Reverse revolution	0
		Bit3	Selection of feed speed without remainder compensation (REMCUT)	Usually set "0."	0
		Bit4 to 7	Filter type selection (FILTERTYPE)	Set the type of the acceleration/deceleration filter. 0: No filter available 1: Exponential acceleration/deceleration filter 2: Moving average filter Setting "1" or "2" will make the filter time constant (OWxx14) valid. Also refer to Section 1.5.2, "Types of Acceleration/Deceleration."	0
		Bit8 to 11	Reserved	Set "0."	0
		Bit12	Reverse revolution limit signal selection for zero point return (LMT_L)	Functions as reverse revolution limit signal on zero point return when the reverse revolution limit signal selection for zero point return (Bit 3 of the additional function selection for use) of the motion fixed parameter is set to OBxx21C. For this reason, it is necessary to connect (program) the external signal (the DI signal taken into by the LIO_01 module, etc.) to OBxx21C by the user's program. Refer to Section 3.3, "Zero point return" for the operation of zero point return.	0
		Bit13	Forward revolution limit signal selection for zero point return (LMT_R)	Functions as forward revolution limit signal on zero point return when the forward revolution limit signal selection for zero point return (Bit 4 of the additional function selection for use) of the motion fixed parameter is set to OBxx21D. For this reason, it is necessary to connect (program) the external signal (the DI signal taken into by the LIO_01 module, etc.) to OBxx21D by the user's program. Refer to Section 3.3, "Zero point return" for the operation of zero point return.	0
Bit14	Position buffer write (BUF_W)	Turning ON this bit will cause the data which have been set to the absolute position buffer write data (OLxx3A) to be stored as absolute position data in the position buffer which has been set by the position buffer access No. (OLxx38). Also refer to Section 3.1.4, "Position Command."	0		

(to be continued)

Table 5.5 Details of Motion Set Parameters

(continued)

No.	Name	Register No.	Setting range	Description	Default value
34	Motion command control flag (MCMDCTRL)	Bit15	Position buffer read-out (BUF_R)	Turning this bit ON will cause data to be read out from the position buffer designated by the position buffer access No. (OLxx38) to be stored at the position buffer read-out data (ILxx28). This bit is used for checking the position data stored at the position buffer. It should be noted that it takes 2 scans from the issue of the read-out command (this bit is turned "ON") until the data is stored at the position buffer read-out data (ILxx28). Also refer to Section 3.1.4, "Position Command."	0
35	Rapid feed speed (RV)	OLxx22	0 to $2^{31}-1$	When the speed command value selection (OBxx01D) is set to "0", this bit allows for setting the rapid feed speed in 10 ⁿ command unit / min (n: the number of decimal places). For each setting unit, For units of pulse: 1=100 pulse/min For units of mm: 1=1mm/min For units of deg: 1=1deg/min For units of inch: 1=1inch/min	0
37	Reserved			Set "0."	0
39	Stopping distance (STOPDIST)	OLxx26	-2^{31} to $2^{31}-1$	Reserved for system use. Do not use.	0
41	Amount of STEP movement (STEP)	OLxx28	0 to $2^{31}-1$	Valid when the motion command (OWxx20) is at the constant step feed. Set the amount of movement in the 1 command unit. Refer to Section 3.1.1, "Command Unit" for the command unit.	0
43	Final travel distance for zero point return (ZRNDIST)	OLxx2A	-2^{31} to $2^{31}-1$	Valid when the motion command (OWxx20) is at the zero point return. This bit allows for moving the distance set by this register after having detected a valid zero point pulse to stop at a position which then be taken as the machine coordinate zero point. Refer to Section 3.3, "Zero point return" for the operation of zero point return.	0
45	Override (OV)	OWxx2C	0 to 32767	An override value is set when the override validity selection (Bit 9 of the motion controller function selection flag) of the motion fixed parameter is set to "Valid." The override means a function to "change to use" the setting of the feed speed. For example, the speed command setting is multiplied (100 % =1.0) by the value set by this register to take this result as the speed command.	10000
46	Position control flag (POSCTRL)	OWxx2D	Selects a function related to the position information controlled by this module. Made up of bits. The bit configuration is as shown below.		
		Bit0	Machine lock mode setting (MLK)	The motion command is executed as usual and the calculated position of machine coordinate system (ILxx02) is updated, however, this is a mode where the actual control axis is locked and disabled to move because pulse output is not available. This bit becomes valid after the completion of issue (IBxx152 is turned "ON") when it is changed.	0
		Bit1	Preset inquiry for the number of POSMAX turns (TPRSREQ)	Turning "ON" this bit will allow for presetting the number of POSMAX turns (ILxx1E) using the data set by the preset data of the number of POSMAX turns (OLxx30). Use this bit to reset to "0."	0
		Bit2 to 15	Reserved	Set "0."	0
47	Offset of work coordinate system (OFFSET)	OLxx2E	-2^{31} to $2^{31}-1$	Usually set it to "0." No direct use is required for this module.	0

(to be continued)

Table 5.5 Details of Motion Set Parameters

(continued)

No.	Name	Register No.	Setting range	Description	Default value
49	Preset data of the number of POSMAX turns (TURNPRS)	OLxx30	-2^{31} to $2^{31}-1$	Turning "ON" the preset inquiry for the number of POSMAX turns (OBxx2D1) allows for presetting the number of POSMAX turns (ILxx1E) using the data set by this register. Used also for resetting to "0."	0
51	Reserved	OWxx32		Set "0."	0
52	Zero point position output width (PSETWIDTH)	OWxx33	0 to 65535	Sets the range of the zero point position. When $0 \leq \text{Machine coordinate command position (ILxx18)} \leq \text{Zero point position output width}$ and the zero point return is under completion (IBxx156 is "ON"), the zero point position (IBxx171) is turned "ON."	10
53 to 56	Reserved	OWxx34 to OWxx37		Set "0."	0
57	Position buffer access No.	OLxx38	1 to 256	Designates the buffer No. of the position buffer when the position buffer write (OBxx21E) is "ON" or the position buffer read-out (OBxx21F) is "ON."	0
59	Position buffer write data	OLxx3A	-2^{31} to $2^{31}-1$	Writes the absolute position data set by this register into the position buffer designated by OLxx38 when the position buffer write (OBxx21E) is "ON."	0
61 to 63	Reserved	OWxx3C to OWxx3F		Set "0."	0

5.2.3 Details of Motion Monitor Parameters

Note

Register numbers are inconsecutive for registers of different module Nos. When module Nos. are the same, registers between axes are consecutive. Therefore, care should be taken when a subscript (i, j) is used in the user's program.

(Example)

For $IW(OW)C000i$, reading is performed without any error for $i=0$ up to 255. For $IW(OW)C000$, the range of registers of module No.1, that is, the range from $IW(OW)C000$ to $IW(OW)C0FF$, can be normally read and written. However, reading cannot be correctly performed for $i \geq 256$.

Table 5.6 Details of Motion Monitor Parameters

No.	Name	Register No.	Range	Description	
1	Run status (RUNSTS)	IWxx00		Reports the running status of the module. Made up of bits. The bit configuration is shown below.	
		Bit0	Reserved		
		Bit1	Motion set parameter setting error (PRMERR)		In setting the motion set parameters (OWxx00 to OWxx3F), this bit is turned ON when setting is performed beyond the setting range. The latest motion set parameter No. which has caused the range over error is reported to the range over occurrence parameter No. (IWxx0F).
		Bit2	Motion fixed parameter setting error (FPRMERR)		In setting the motion fixed parameters, this bit is turned ON when setting is performed beyond the setting range. The latest motion fixed parameter No., which has caused the range over error, added by 100 is reported to the range over occurrence parameter No. (IWxx0F). This bit is automatically turned OFF when a correct motion fixed parameter is set by the CP-717.
		Bit3 to 6	Reserved		
		Bit7	Motion controller running preparation completion (SVCRDY)		The module is turned ON at the completion of running preparation. This bit is turned "OFF" (1) when a serious failure has occurred, (2) when the axis has been selected for no use (motion fixed parameter setting), (3) when an error has occurred in motion fixed parameter setting, and (4) while the motion fixed parameter is being changed.
		Bit8	Motion controller in running (SVCRUN)		This bit is turned "ON" when the above SVCRDY (IBxx007) is "ON" in the position control mode (OBxx002 is "ON") and the magnetization-ON (OBxx010) is "ON" (at the rise). This bit will be turned "OFF" when the emergency stop (DI04) is input. When an alarm is on with this bit "ON", the axis will not move even when a motion command is issued. In this case, clear the alarm and then set the motion command to NOP for one scan or more to reset the motion command.
		Bit9 to 12	Reserved		
		Bit13	Positioning completion signal (POSCOMP)		This bit is turned "ON" on completion of positioning. For example, the issue completion (IBxx152) turns this bit "ON."
		Bit14	Reserved		
Bit15	Reserved				
2	General-purpose DI monitor (SVSTS)	IWxx01		Reports the signal status of the input signal, dedicated DI signal, or general-purpose DI signal from the pulse motor driver. DI00 to DI03 are available as dedicated signal for zero point return. DI04 is the dedicated signal for the emergency stop/decelerating to stop signal. DI01 to DI03 are available as general-purpose DI. Made up of bits. This bit configuration is shown below.	
		Bit0	Zero point signal/general-purpose DI (HW_ZERO/DI0)	Reports the signal status of DI00. DI00 functions as zero point signal for zero point return. Except for zero point return, DI00 can be used as general-purpose DI.	
		Bit1	Limit switch signal/general-purpose DI (DEC/DI1)	Reports the signal status of DI01. DI01 is available for selection of whether or not to use it as the limit switch signal for zero point return or as general-purpose DI, which is allowed by selecting the limit switch signal selection (Bit 2 of the additional function selection for use) of the motion fixed parameter. Refer to the motion fixed parameter for details.	

(to be continued)

Table 5.6 Details of Motion Monitor Parameters

(continued)

No.	Name	Register No.	Range	Description
2	General-purpose DI monitor (SVSTS)	Bit2	Reverse revolution limit signal for zero point return/ general-purpose DI (LMT_L/DI2)	Reports the signal status of DI02. DI02 is available for selection of whether or not to use it as the reverse revolution limit signal for zero point return or as general-purpose DI, which is allowed by selecting the limit switch signal selection (Bit 3 of the additional function selection for use) of the motion fixed parameter. Refer to the motion fixed parameter for details.
		Bit3	Forward revolution limit signal for zero point return/ general-purpose DI (LMT_R/DI3)	Reports the signal status of DI03. DI03 is available for selection of whether or not to use it as the forward revolution limit signal for zero point return or as general-purpose DI, which is allowed by selecting the limit switch signal selection (Bit 4 of the additional function selection for use) of the motion fixed parameter. Refer to the motion fixed parameter for details.
		Bit4	Emergency stop signal/ decelerating to stop signal (EMRGNCY) (DI4)	Reports the signal status of DI04. Displays the status of not the DI04 signal itself but of latched signal. When DI04 is input, the signal is latched and this bit is held "1" until the emergency stop / decelerating to stop signal release (OBxx01B) is turned "OFF"→ "ON" with the magnetization-ON (OBxx010) being "OFF." Running is not allowed when this bit is "1." When this bit is turned ON, the LED's of the module display as "┘" (axis 1), "└" (axis 2), "┐" (axis 3), or "┑" (axis 4).
		Bit5 to 15	Reserved	
3	Machine coordinate calculated position (CPOS)	ILxx02	-2^{31} to $2^{31}-1$	The machine coordinate calculated position which the module controls is reported. The position data to be reported to this register becomes usually the target position for every scan. Also refer to Section 3.1.4, "Position command (2) Position Monitor."
5	Target position increment monitor (PTGDIF)	ILxx04	-2^{31} to $2^{31}-1$	The amount of movement of the issue for each scan is reported in 1=1 command unit.
7 to 15	Reserved	IWxx06 to IWxx0E		
16	Parameter number for range overrun occurrence (ERNO)	IWxx0F	(1) For the motion set parameter 1 to 65 (2) For the motion fixed parameter 101 to 148	In the setting of the motion set parameters (OWxx00 to OWxx3F) or motion fixed parameters, the latest parameter No. which has been set beyond the setting range is reported. When a setting range over error has been detected in the setting of the motion set parameters (OWxx00 to OWxx3F), 1 to 65 is reported as parameter No. When range over error has been detected in the setting of the motion set parameters, the motion fixed parameter No. added by 100 (101 to 148) is reported as parameter No. For example, when a setting range over error has been detected in setting the linear acceleration time constant (OWxx0C), 00013 is to be reported. When a setting range over error has been found in the number of the rated revolution (a motion fixed parameter), 00107 is to be reported. (Note) Valid when the motion set parameter setting error (IBxx001) or motion fixed parameter setting error (IBxx002) is ON.
17 to 20	Reserved	IWxx10 to IWxx13		
21	Motion command response code (MCMDCODE)	IWxx14	0 to 65535	The motion command (OWxx20) under execution is reported. Refer to OWxx20 for motion commands.
22	Motion command status (MCM DSTS)	Reports the execution status of the motion command (OWxx20). Made up of bits. The bit configuration is as shown below.		
		Bit0	Command under-execution flag (BUSY)	Reports the status of the motion command. 0: Ready (Accomplished) 1: BUSY (under processing) This bit is used in particular as status during suspension.
		Bit1	Command suspension completion flag (HOLDL)	Turned "ON" when suspension has been finished. Refer to each motion function for the suspension function.
		Bit2	Issue completion (DEN)	Turned "ON" when the issue of movement amount has been completed.

(to be continued)

Table 5.6 Details of Motion Monitor Parameters

(continued)

No.	Name	Register No.	Range	Description	
22	Motion command status (MCMDDSTS)	Bit3	Zero point setting completion (ZSET)	Turned "ON" when the zero point setting (ZSET) is issued to the motion command (OWxx20) and completed.	
		Bit4	Reserved		
		Bit5	Command abnormal termination status (FAIL)	Turned "ON" when an alarm has been given for a reason during the execution of move command (positioning, constant speed feed, etc.). Running is not allowed when this bit is "ON." When this bit is "ON", turn the motion command (OWxx20) to "NOP" for one scan or more. When this bit is turned ON, the LED's of the module display as "L" (axis 1), "L" (axis 2), "L" (axis 3), or "L" (axis 4).	
		Bit6	Zero point return completion status (ZRNC)	Turned "ON" at the time of completion of zero point return or zero point setting. Turned "OFF" at the start of zero point return.	
		Bit7 to 15	Reserved		
23	Monitor for the number of decimal places (DECNUMM)	IWxx16	0 to 5	The motion fixed parameter No.18, "Number of Decimal places", is reported.	
24	Position control status (POSSTS)	IWxx17			Reports the status related to the position controlled by the module. Made up of bits. The bit configuration is shown below.
		Bit0	Under machine-lock (MLKL)	Turned "ON" under the condition of machine lock. When this bit is "ON", the output of a command pulse is not performed. Consequently, the actual control axis is locked and held stopped.	
		Bit1	Zero point position (ZERO)	This bit is turned "ON" when the zero point return is under completion (IBxx156 is "ON") and $0 \leq \text{Machine coordinate command position (Lxx18)} \leq \text{Zero point position output width (OWxx33)}$.	
		Bit2	Second INP completion(PSET2)	Available for motion functions. This bit is turned "ON" on completion of issue (IBxx152).	
		Bit3	Reserved		
		Bit4	Presetting completion for the number of POSMAX turns (TPRSE)	Valid when the axis selection of the motion fixed parameter (Bit 5 of the motion controller function selection flag) is set to the infinite length axis (=1). When the preset inquiry for the number of POSMAX turns (OBxx2D1) is "ON", this bit is turned "ON" at the completion of presetting. Turning "OFF" the presetting inquiry for the number of POSMAX turns will turn this bit "OFF."	
		Bit5	Electronic gear selection (GEARM)	The motion fixed parameter No.17, Bit 4 "Electronic Gear Selection", is reported.	
		Bit6	Axis selection (MODSELM)	The motion fixed parameter No.17, Bit 5 "Axis Setting", is reported.	
Bit7 to 15	Reserved				
25	Machine coordinate command position (MPOS)	ILxx18	-2^{31} to $2^{31}-1$	The position which the module outputs in a pulse train, that is, the machine coordinate command position is reported. This position data is not updated under machine lock status (IBxx170 is "ON"). Also refer to Section 3.1.4, "Position Command (2) Position Monitor."	
27	Reserved	ILxx1A			
29	POSMAX monitor (PMAXTURN)	ILx1C	1 to $2^{31}-1$	The motion fixed parameter No.23, "Resetting position of infinite length axis (POSMAX)" is to be reported.	
31	The number of POSMAX turns (PMAXTURN)	ILxx1E	-2^{31} to $2^{31}-1$	Valid when the axis selection of the motion fixed parameter (Bit 5 of the motion controller function selection flag) is set to the infinite length axis (=1). This bit goes up/down every time the motion fixed parameter No.23, "Reset position of the infinite length axis (POSMAX)" is exceeded. Can be preset by the preset data for the number of POSMAX turns of the motion set parameter (OLxx30) or by the preset inquiry for the number of POSMAX turns (OBxx2D1).	
33	Reserved	ILxx20			
35	Alarm (ALARM)	ILxx22		Alarm information is reported. Running is not allowed except for the register being "0." The rise of the alarm clear (OBxx006) clears this register to "0." When this bit is other than "0", the LED's of the module display as "L" (axis 1), "L" (axis 2), "L" (axis 3), or "L" (axis 4). Made up of bits. The bit configuration is shown below.	
		Bit0 to 2	Reserved		

(to be continued)

Table 5.6 Details of Motion Monitor Parameters

(continued)

No.	Name	Register No.	Range	Description
35	Alarm (ALARM)	Bit3	Positive direction software limit (SOTF)	When the axis selection of the motion fixed parameter is at the finite length axis, when the software limit (positive direction) of the motion fixed parameter is selected to be valid, and at the status of completion of zero point return (IBxx156 is "ON"), (1) when the motion command (OWxx20) is at the interpolation, when the machine coordinate command position (ILxx18) + stopping distance (OLxx26) \geq software limit value (positive direction) (the motion fixed parameter No.27), this bit is turned "ON." (2) when the motion command (OWxx20) is at the positioning, constant speed feed, or constant step feed, and the machine coordinate command position (ILxx18) \geq software limit value (positive direction) (the motion fixed parameter No.27), this bit is turned "ON."
		Bit4	Negative direction software limit (SOTR)	When the axis selection of the motion fixed parameter is at the finite length axis, when the software limit (negative direction) of the motion fixed parameter is selected to be valid, and at the status of completion of zero point return (IBxx156 is "ON"), (1) when the motion command (OWxx20) is at the interpolation, when the machine coordinate command position (ILxx18) + stopping distance (OLxx26) \leq software limit value (negative direction) (the motion fixed parameter No.29), this bit is turned "ON." (2) when the motion command (OWxx20) is at the positioning, constant speed feed, or constant step feed, and the machine coordinate command position (ILxx18) \leq software limit value (negative direction) (the motion fixed parameter No.29), this bit is turned "ON."
		Bit5	Magnetization OFF (SVOFF)	At the position control mode (when OBxx002 is "ON") and when the magnetization-ON (OBxx010) is turned "OFF", setting the move command (positioning or constant speed feed, etc.) to the motion command (OWxx20) will cause this bit to be turned "ON."
		Bit6	Reserved	
		Bit7	The excessive speed (DISTOVER)	This bit is turned "ON" when the number of pulses beyond the maximum frequency for pulse output available for issuing at a scan is to be output. Refer to Section 1.4.2, "Pulse Output Maximum Frequency" for details.
		Bit8	Reserved	
		Bit9	Reserved	
		Bit10	Control mode error (MODERR)	This bit is turned "ON" when the move command (positioning or constant speed feed, etc.) is set to the motion command (OWxx20) in a mode other than the position control mode (OBxx002 is "OFF").
Bit11 to 31	Reserved			
37	Reserved	IWxx24		
38	Reserved	IWxx25		
39	Speed command output value monitor (RVMON)	ILxx26	-2^{31} to $2^{31}-1$	The amount of movement for every scan is reported. This bit is "0" under the machine lock status (IBxx170 is "ON").
41	Position buffer read-out data	ILxx28	-2^{31} to $2^{31}-1$	When the position buffer read-out of the motion set parameter (OBxx21F) is "ON", the position data is read out from the position buffer designated by the position buffer access No. (OLxx38) to be stored in this register. It should be noted that it takes 2 scans from turning "ON" the position buffer read-out command (OBxx21F) until the data is stored at this register.
43	The number of output pulses (XREFMON)	ILxx2A	-2^{31} to $2^{31}-1$	The number of pulses which are output at every scan by the module is reported. This bit is "0" under the machine lock status (IBxx170 is "ON").
45	Reserved	ILxx2C		
47	Command coordinate calculated position (POS)	ILxx2E	-2^{31} to $2^{31}-1$	Selecting the infinite length axis (=1) at the axis selection of the motion fixed parameter (Bit 5 of the motion controller function selection flag) gives a sense to this bit. The target position at every scan for the infinite length axis is reported. Also refer to Section 3.1.4, "Position command (2) Position Monitor."
49 to 63	Reserved	IWxx30 to IWxx3F		

5.3 Examples of Motion Parameter Setting

5.3.1 Examples of Motion Fixed Parameter Setting

5.7 Examples of Motion Fixed Parameter Setting

No.	Name	Setting range	Description	Setting(examples)
1	Axis use selection (USESEL)	0 or 1 (Default =0)	0: Select for no use 1: Select for use	1
2 to 6	Reserved		Set "0."	-----
7	Rated speed setting (NR)	1 to 32000 (Default =100)	1=1rpm	400
8 to 13	Reserved			-----
14	Additional function selection for use (AFUNCSEL)	Set for each bit. (Default =0080H)	Refer to Table 5.1, "List of Motion Fixed Parameters."	0080 (H)
15	Reserved			-----
16	Reserved			-----
17	Motion controller function selection flag (SVFUNCSEL)	Set for each bit. (Default =0)	Refer to Table 5.1, "List of Motion Fixed Parameters."	0 (H)
18	The number of decimal places (DECNUM)	0 to 5 (Default =3)	Set the number of decimal places of command (Example) For the number of decimal places = 3, mm : One command unit = 0.001 mm deg : One command unit = 0.001 deg inch : One command unit = 0.001 inch This parameter and the command unit selection gives the minimum command unit. However, the minimum unit of "pulse" is not affected by this parameter. This parameter and command unit selection determines the minimum command unit. However, the minimum unit for pulse is not affected by this parameter.	3
19	Amount of movement per one revolution of machine (PITCH)	1 to $2^{31}-1$ (Default =10000)	1=1 command unit	10000
21	Gear ratio of the motor side (GEAR_MOTOR)	1 to 65535 (Default =1)	1=1 revolution	1
22	Gear ratio of the machine side (GEAR_MACHINE)	1 to 65535 (Default =1)	1=1 revolution	1
23	Reset position of infinite- length axis (POSMAX)	1 to $2^{31}-1$ (Default =360000)	1=1 command unit	360000
25	Reserved			-----
27	Software limit value (positive direction) (SLIMP)	-2^{31} to $2^{31}-1$ (Default = $2^{31}-1$)	1=1 command unit	2147483647 (7FFF FFFFH)
29	Software limit value (negative direction) (SLIMN)	-2^{31} to $2^{31}-1$ (Default = -2^{31})	1=1 command unit	-2147483648 (8000 0000H)
31	Zero point return method (ZRETSEL)	0 to 7 (Default =2)	0: Reserved 1: Reserved 2: DEC1 signal (with switch width) + ZERO signal 3: Reserved 4: DEC2 signal (without switch width) + ZERO signal 5: DEC1 signal (with switch width) + LMT (limit signal for zero point return) + ZERO signal 6: Reserved 7: Reserved	DEC1+ZERO signal (=2)
32	Reserved			-----
33	The number of pulses per one revolution of the motor (MPPS)	1 to $2^{31}-1$ (Default =200)	1=1 pulse (The number of pulses per one revolution of the stepping motor)	2000

(to be continued)

5.7 Examples of Motion Fixed Parameter Setting

(continued)

No.	Name	Setting range	Description	Setting(examples)
35	Bias speed (BIASSPD)	0 to 32767 (Default =0)	1=10 ⁿ command unit/min (n: the number of decimal places) For units of pulse: 1=100 pulse/min For units of mm: 1=1mm/min For units of deg: 1=1deg/min For units of inch: 1=1inch/min	0
36	Bias speed for exponential acceleration/deceleration filter (EXPBIAS)	0 to 32767 (Default =0)	1=10 ⁿ command unit/min (n: the number of decimal places) For units of pulse: 1=1000 pulse/min For units of mm: 1=1mm/min For units of deg: 1=1deg/min For units of inch: 1=1inch/min	0
37	Pulse output signal form selection (POSEL)	Set for each bit. (Default =0)	Refer to Table 5.1, "List of Motion Fixed Parameters."	0 (H)
38	Pulse output maximum frequency (MAXHZ)	1 to 50 (Default =10)	1=10kHz(10 to 500kHz) Note: Set one of 1 (10 kHz), 2 (20 kHz), 4 (40 kHz), 5 (50 kHz), 8 (80 kHz), 10 (100 kHz), 20 (200 kHz), 25 (250 kHz), 40 (400 kHz), and 50 (500 kHz). Be sure to set a value common to 4 axes including the unused axes.	10 (100kHz)
39 to 48	Reserved			-----

(Note): The above setting is an example. Set a relevant value to fit your machine.

5.3.2 Examples of Motion Set Parameter Setting

The parameters are used for commanding the motion control module. At the beginning of high-speed scan, the parameters are transferred to the motion control module in a batch. Motion control can be performed only by setting the parameters to the register regions.

5.8 Examples of Motion Set Parameter Setting

No.	Name	Register No.	Setting range	Description	Setting(examples)				
					Positioning	Zero point return	Interpolation	Constant speed feed	Constant step feed
1	Run mode setting (RUNMOD)	OWxx00	Set for each bit. (Default =0100H)		0104H	0104H	0104H	0104H	0104H
2	Run command setting (SVRUNCMD)	OWxx01	Set for each bit. (Default =0)		0001H	0001H	0001H	0001H	0001H
3 to 6	Reserved	OWxx02 to OWxx05	Set "0."		-----				
7	Machine coordinate zero point offset setting (ABSOFF)	OLxx06	-2^{31} to $2^{31}-1$ (Default =0)	1=1 command unit (1=1 pulse for the pulse unit)	0	0	0	0	0
9	Reserved	OLxx08	Set "0."		-----				
11	Approach speed setting (Napr)	OWxx0A	0 to 32767 (Default =0)	The unit differs depending on the speed command value selection (OBxx01D). For the speed command value selection =0, 1=10 ⁿ command unit/min (n: the number of decimal places) For units of pulse: 1=100 pulse/min For units of mm: 1=1mm/min For units of deg: 1=1deg/min For units of inch: 1=1inch/min For the speed command value selection =1, 1=0.01%(1000=10.00%)	800				
12	Creep speed setting (Nclp)	OWxx0B	0 to 32767 (Default =0)		400				
13	Linear acceleration time constant (NACC)	OWxx0C	0 to 32767 (Default =0)	1=1ms (300=0.300s)	500	500	500	500	500
14	Linear deceleration time constant (NDEC)	OWxx0D	0 to 32767 (Default =0)	1=1ms (300=0.300s)	500	500	500	500	500
15 to 18	Reserved	OWxx0E to OWxx11	Set "0."		-----				
19	Position reference setting (XREF) or position buffer No.	OLxx12	-2^{31} to $2^{31}-1$ (Default =0)	1=1 command unit (1=1 pulse for the pulse unit) * For position command value selection (OBxx01C)=1, the position buffer No. (1 to 256).	1000 0	0002 0	0	0	0
21	Filter time constant (NNUM)	OWxx14	(1) For Bit 4 through 7 of OWxx21 equal to "2," the S-curve (Moving Average) time constant 0 to 255 (1=1 time) (0=1=without averaging) (Default =0) (2) For Bit 4 through 7 of OWxx21 equal to "1," the exponential acceleration/deceleration time constant 0 to 32767 (1=1 ms) (Default =0)		0	0	0	0	0
22	Speed reference setting (NREF)	OWxx15	0 to 32767 (Default =0)	1=0.01% (5000=50.00%)	0	0	0	0	0
23 to 30	Reserved	OWxx16 to OWxx1D	Set "0."		-----				
31	Offset pulse setting (PULBIAS)	OLxx1E	-2^{31} to $2^{31}-1$ (Default =0)	1=1 pulse	0	0	0	0	0

(to be continued)

5.8 Examples of Motion Set Parameter Setting

(continued)

No.	Name	Register No.	Setting range	Description	Setting(examples)				
					Positioning	Zero point return	Interpolation	Constant speed feed	Constant step feed
33	Motion command code (MCMDCODE)	OWxx20	0 to 65535 (Default =0)	0: NOP No command available 1: POSING Positioning 2: Reserved 3: ZRET Zero point return 4: INTERPOLATE Interpolation 5: END_OF_INTERPOLATE Final Interpolation segment 6: Reserved 7: FEED Constant speed feed 8: STEP Constant step feed 9: ZSET Zero point setting 10 to 65535: Reserved	1	3	4	7	8
34	Motion command control flag (MCMDCTRL)	OWxx21	Set for each bit. (Default =0)		0000H	0000H	0000H	0000H	0000H
35	Rapid feed speed (RV)	OLxx22	0 to 2 ³¹ -1 (Default =0)	1=10 ⁿ command unit/min (n: the number of decimal places) For units of pulse: 1=100 pulse/min For units of mm: 1=1mm/min For units of deg: 1=1deg/min For units of inch: 1=1inch/min	4000	4000	/	4000	4000
37	Reserved	OLxx24		Set "0."	/	/	/	/	/
39	Stopping distance (STOPDIST)	OLxx26	-2 ³¹ to 2 ³¹ -1 (Default =0)	1=1 command unit	/	/	0	/	/
41	Amount of STEP movement (STEP)	OLxx28	0 to 2 ³¹ -1 (Default =0)	1=1 command unit	/	/	/	/	2000
43	Final travel distance for zero point return (ZRNDIST)	OLxx2A	-2 ³¹ to 2 ³¹ -1 (Default =0)	1=1 command unit	/	20	/	/	/
45	Override (OV)	OWxx2C	0 to 32767 (Default = 10000=100%)	1=0.01%	1000 0	1000 0	/	1000 0	1000 0
46	Position control flag (POSCTRL)	OWxx2D	Set for each bit. (Default =0)		0000H	0000H	0000H	0000H	0000H
47	Work coordinate system Offset (OFFSET)	OLxx2E	-2 ³¹ to 2 ³¹ -1 (Default =0)	1=1 command unit (For units of pulse: 1=1 pulse)	0	0	0	0	0
49	Preset data of the number of POSMAX turns (TURNPRS)	OLxx30	-2 ³¹ to 2 ³¹ -1 (Default =0)	1=1 revolution	0	0	0	0	0
51	Reserved	OWxx32		Set "0."	/	/	/	/	/
52	Zero point position output width (PSETWIDTH)	OWxx33	0 to 65535 (Default =10)	1=1 command unit	10	10	10	10	10

(to be continued)

5.8 Examples of Motion Set Parameter Setting

(continued)

No.	Name	Register No.	Setting range	Description	Setting(examples)				
					Positioning	Zero point return	Interpolation	Constant speed feed	Constant step feed
53 to 56	Reserved	OWxx34 to OWxx37		Set "0."	-----				
57	Position buffer access No.	OLxx38	1 to 256 (Default =0)	Position buffer access No. (0= Invalid)	0	0	0	0	0
59	Position buffer data for write	OLxx3A	-2^{31} to $2^{31}-1$ (Default =0)		0	0	0	0	0
61 to 63	Reserved	OWxx3C to OWxx3F		Set "0."	-----				

(Note 1): The above setting is an example. Set a relevant value to fit your machine.

(Note 2): The diagonally lined boxes show areas not used in motion function. Set corresponding default values.

Machine Controller CP-9200SH/PO-01

MOTION CONTROLLER

USER'S MANUAL

TOKYO OFFICE

New Pier Takeshiba South Tower, 1-16-1, Kaigan, Minatoku, Tokyo 105-6891 Japan
Phone 81-3-5402-4502 Fax 81-3-5402-4580

YASKAWA ELECTRIC AMERICA, INC.

2121 Norman Drive South, Waukegan, IL 60085, U.S.A.
Phone 1-847-887-7000 Fax 1-847-887-7370

MOTOMAN INC. HEADQUARTERS

805 Liberty Lane West Carrollton, OH 45449, U.S.A.
Phone 1-937-847-6200 Fax 1-937-847-6277

YASKAWA ELÉTRICO DO BRASIL COMÉRCIO LTD.A.

Avenida Fagundes Filho, 620 Bairro Saude-Sao Paulo-SP, Brazil CEP: 04304-000
Phone 55-11-5071-2552 Fax 55-11-5581-8795

YASKAWA ELECTRIC EUROPE GmbH

Am Kronberger Hang 2, 65824 Schwalbach, Germany
Phone 49-6196-569-300 Fax 49-6196-569-398

Motoman Robotics Europe AB

Box 504 S38525 Torsås, Sweden
Phone 46-486-48800 Fax 46-486-41410

Motoman Robotec GmbH

Kammerfeldstraße 1, 85391 Allershausen, Germany
Phone 49-8166-90-100 Fax 49-8166-90-103

YASKAWA ELECTRIC UK LTD.

1 Hunt Hill Orchardton Woods Cumbernauld, G68 9LF, United Kingdom
Phone 44-1236-735000 Fax 44-1236-458182

YASKAWA ELECTRIC KOREA CORPORATION

Kipa Bldg #1201, 35-4 Youido-dong, Yeongdungpo-Ku, Seoul 150-010, Korea
Phone 82-2-784-7844 Fax 82-2-784-8495

YASKAWA ELECTRIC (SINGAPORE) PTE. LTD.

151 Lorong Chuan, #04-01, New Tech Park Singapore 556741, Singapore
Phone 65-6282-3003 Fax 65-6289-3003

YASKAWA ELECTRIC (SHANGHAI) CO., LTD.

No.18 Xizang Zhong Road, Room 1805, Harbour Ring Plaza Shanghai 20000, China
Phone 86-21-5385-2200 Fax 86-21-5385-3299

YATEC ENGINEERING CORPORATION

4F., No.49 Wu Kong 6 Rd, Wu-Ku Industrial Park, Taipei, Taiwan
Phone 886-2-2298-3676 Fax 886-2-2298-3677

YASKAWA ELECTRIC (HK) COMPANY LIMITED

Rm. 2909-10, Hong Kong Plaza, 186-191 Connaught Road West, Hong Kong
Phone 852-2803-2385 Fax 852-2547-5773

BEIJING OFFICE

Room No. 301 Office Building of Beijing International Club, 21
Jianguomenwai Avenue, Beijing 100020, China
Phone 86-10-6532-1850 Fax 86-10-6532-1851

TAIPEI OFFICE

9F, 16, Nanking E. Rd., Sec. 3, Taipei, Taiwan
Phone 886-2-2502-5003 Fax 886-2-2505-1280

SHANGHAI YASKAWA-TONGJI M & E CO., LTD.

27 Hui He Road Shanghai China 200437
Phone 86-21-6553-6060 Fax 86-21-5588-1190

BEIJING YASKAWA BEIKE AUTOMATION ENGINEERING CO., LTD.

30 Xue Yuan Road, Haidian, Beijing P.R. China Post Code: 100083
Phone 86-10-6233-2782 Fax 86-10-6232-1536

SHOUGANG MOTOMAN ROBOT CO., LTD.

7, Yongchang-North Street, Beijing Economic Technological Investment & Development Area,
Beijing 100076, P.R. China
Phone 86-10-6788-0551 Fax 86-10-6788-2878



YASKAWA ELECTRIC CORPORATION

YASKAWA

In the event that the end user of this product is to be the military and said product is to be employed in any weapons systems or the manufacture thereof, the export will fall under the relevant regulations as stipulated in the Foreign Exchange and Foreign Trade Regulations. Therefore, be sure to follow all procedures and submit all relevant documentation according to any and all rules, regulations and laws that may apply.

Specifications are subject to change without notice for ongoing product modifications and improvements.

© 1998-2003 YASKAWA ELECTRIC CORPORATION. All rights reserved.

MANUAL NO. SIE-C879-40.4B

© Printed in Japan July 2003 98-3
03-4⑤ 98-87126